



DAS HERZ DER FRISCHE

SEMI-HERMETIC COMPACT SCREW COMPRESSORS

50 Hz // SP-170-10 EN





WITH IQ MODULE



CSH // CSW



CSVH // CSVW

-  AIR
CONDITIONING
-  PROCESS
COOLING
-  HEAT
PUMPS



BITZER Innovation Targets

Products for refrigerants with low global warming potential (GWP)

- // For natural refrigerants
- // For refrigerants like R1234yf, R1234ze(E) and low-GWP blends

These refrigerants reduce the direct contribution of refrigeration systems to global warming.

Products with high efficiency at full and part load

- // Efficiency improvements of motor and mechanics
- // High system efficiency in part load operation
 - by optimised mechanical capacity regulation
 - by specially developed frequency inverters

This reduces the indirect contribution to global warming by saving energy.

Simple handling and serviceability with advanced electronic modules

- // Electronic components for
 - data logging
 - capacity regulation
 - actuation of accessories
- // Unified user software for simple configuration. Choose compressor or condensing unit and refrigerant. Ready.

This makes it simple to fully utilize the efficiency potential of our products and optimise operation.

Semi-hermetic Compact Screw Compressors

Series: CSH // CSW // CSVH // CSVW

Content	Page
One basic structure – application-optimised specialists	4
CSW	6
Applications	6
Application limits	7
CSW105	8
Capacity control (CR) and V_i	9
CSH	10
Applications	10
Application limits	11
Refrigerants with very low global warming potential	12
CS PRO	12
CSVH and CSVW	14
Applications	15
Application limits	16
Tuned-in electrics	17
Permanent magnet motor	17
Accessories for CSH, CSW, CSVH and CSVW	18
Heat pump application	24
CSH2T	25
Model designation	26
Technical data	28
CSH	28
CS PRO	29
Compressors for high temperature heat pumps	30
CSW	31
CSVH and CSVW	32
Dimensional drawings	33

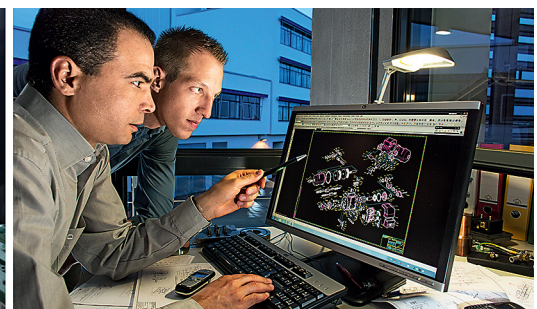
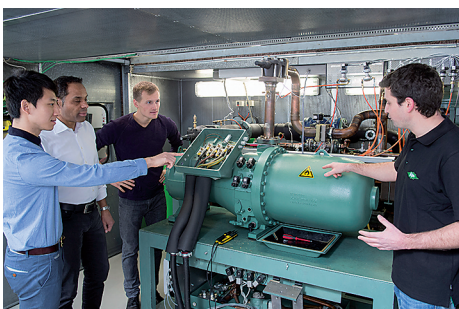

The CSH, CSW, CSVH and CSVW compact screw compressors

The semi-hermetic compact compressors of the CS. series are screw compressors which have been developed for the application in compact refrigeration systems, in liquid chillers for air conditioning and process cooling, and in heat pumps. Many functions are integrated, such as oil separator, slider capacity control, check valve in discharge gas outlet and Economiser operation (ECO) and, depending on design, connections for oil cooling, liquid injection (LI) or oil return. With CSV. series even the frequency inverter is integrated. These compact refrigeration systems flexibly adapt to the various needs of the application.

Special features

- // Energy efficient
 - high efficiency profile
 - stepless or closely stepped capacity control
- // Compact
 - shortest fitting length in its performance class
- // Flexible
 - CS. Series: dual capacity control: changeable between 4-step or stepless capacity control – without modifying the compressor
 - suction and discharge gas connections can be rotated in 90° increments

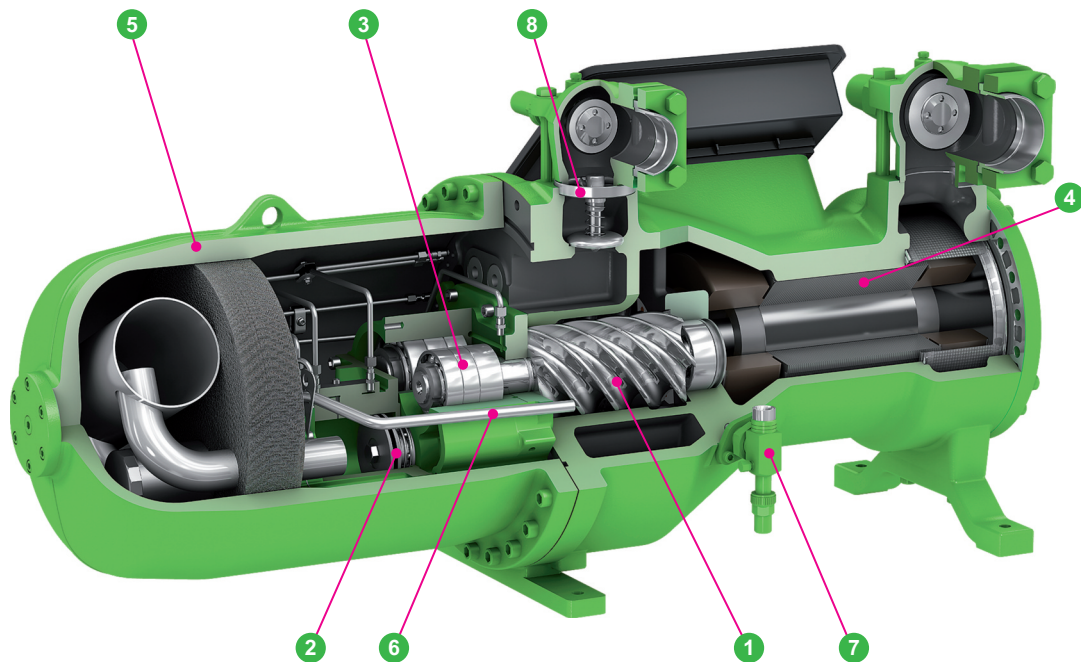

- ① high efficiency profile
- ② control slider: Part load down to 25% of full load
- ③ long-life bearings with pressure unloading
- ④ specially adapted built-in motor
- ⑤ integrated oil separator
- ⑥ optimized oil management
- ⑦ economiser (ECO)
- ⑧ integrated check valve

High energy efficiency at full and part load

- // CS. series: suitable for operation with external frequency inverter (FI)
 - within the full application range
 - control range depending on operating conditions
- // CSV. series: integrated frequency inverter for systems with particularly high demands
 - on wide control ranges
 - on high control quality
 - on high part load efficiency

One basic structure – application-optimised specialists

CSW

This version is designed for lower condensing temperatures, i. e. for air cooled liquid chillers in cooler regions, or for water cooled liquid chillers in general. It provides a high efficiency at these typical operating points and still has some reserves towards lower evaporating temperatures needed in medium temperature process cooling, for example.

CSW with motor 4

This version is optimised for highly efficient water cooled liquid chillers, where it can fully exploit its energy saving potential.

CSWW

This version is designed for slightly lower condensing temperatures and shows its advantages whenever the combination of high efficiency with fine control is required in liquid chillers for air conditioning and process cooling

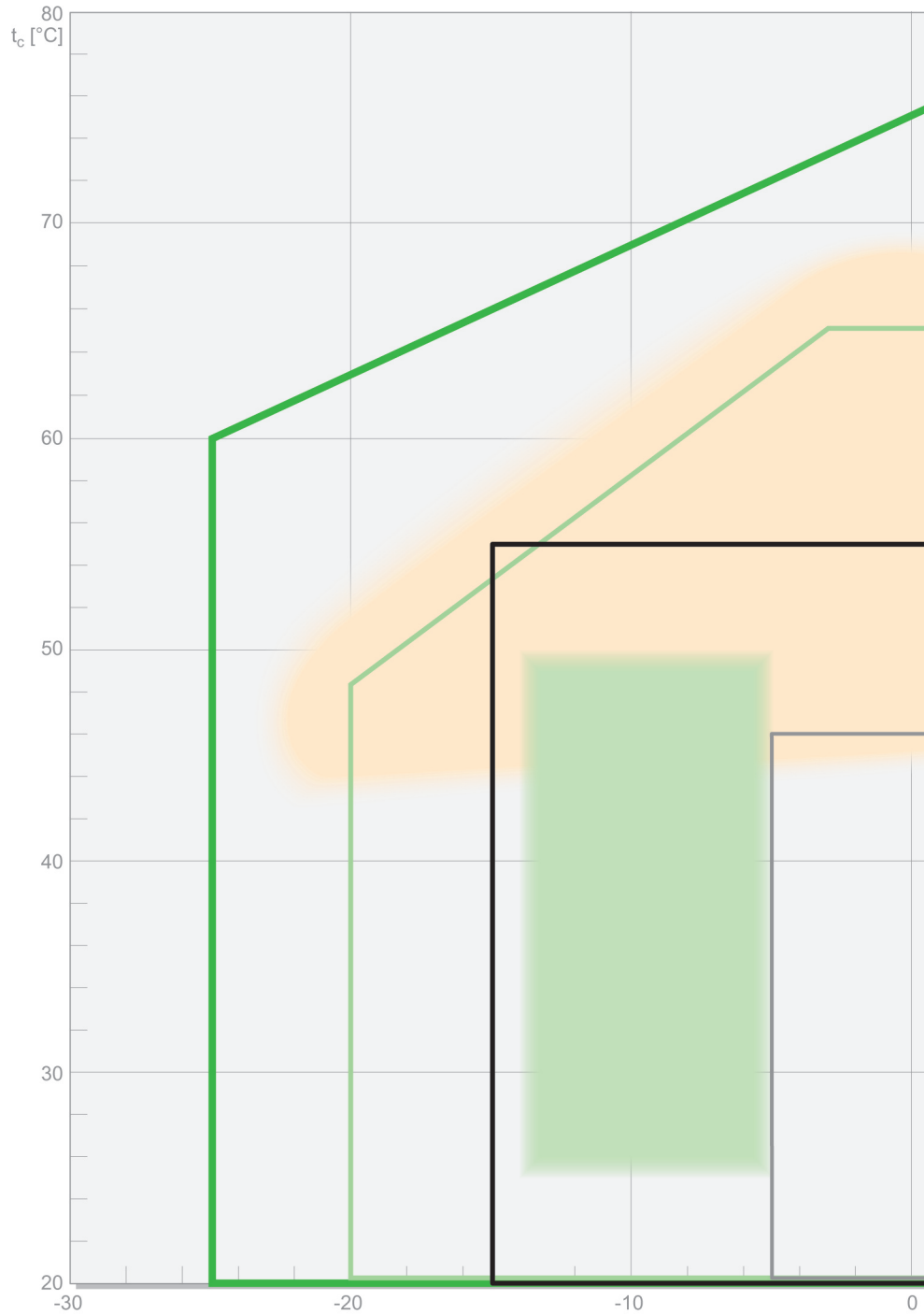

Exemplary applications

- Heat pump operation air conditioning liquid chillers
- Medium temperature process application
- Building air conditioning

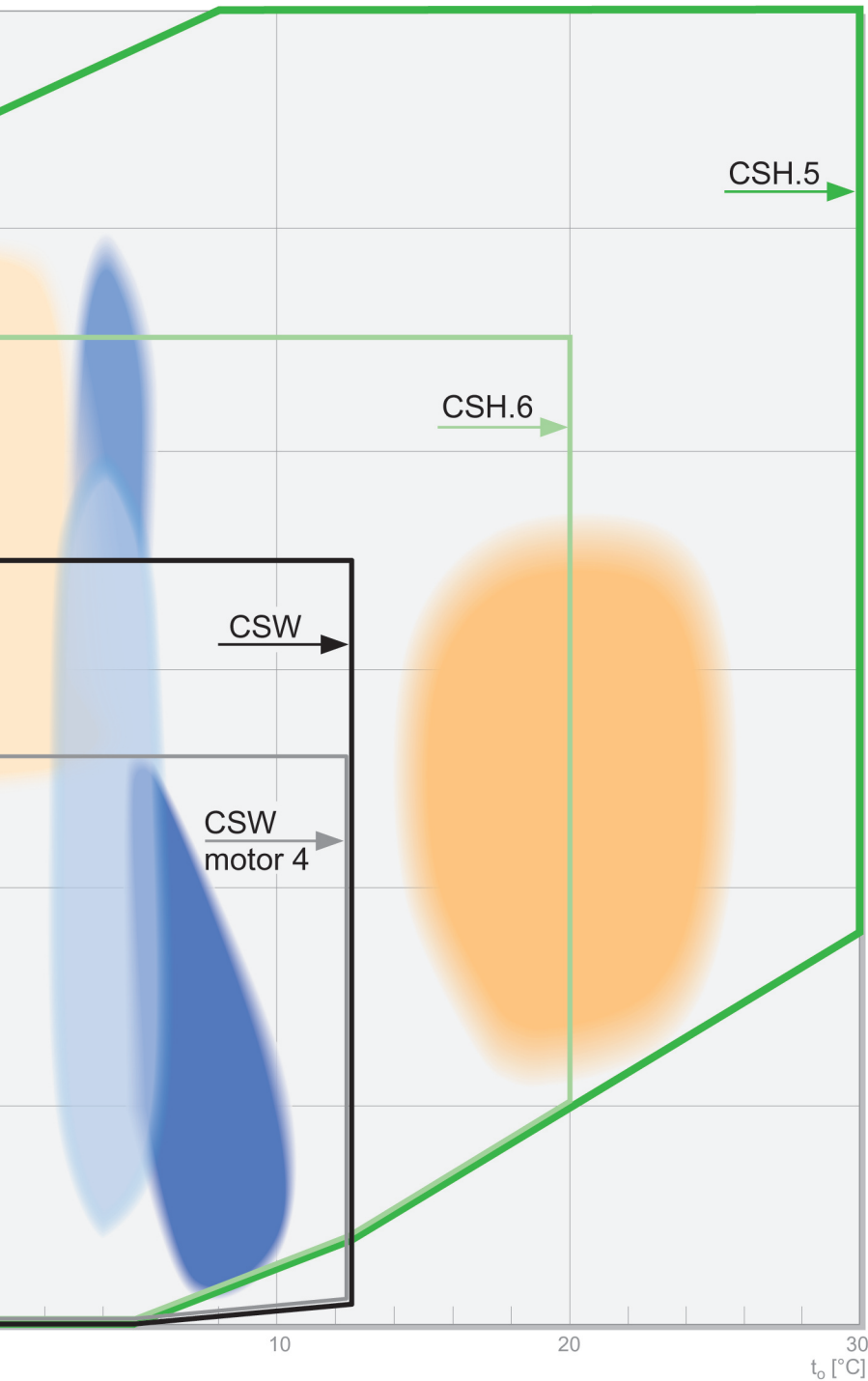

- Building air conditioning at high ambient temperatures
- Highly optimised air conditioning applications
- Data center cooling

CSH.5

This universal version has the largest application range. Motor 1 is designed for data center cooling and for air conditioning by means of air cooled liquid chillers in hot countries, like Middle East. The CSH.5 manages heat pump operation with high condensing temperatures as well as low evaporating temperatures.

CSH.6

This design aims at air cooled liquid chillers in temperate and cold regions, where it achieves an even better efficiency. The application limits fit to moderate data center cooling and typical heat pump operation of liquid chillers for air conditioning.

CSVH

Similar to the CSH.6, this design is tailored to air cooled liquid chillers, but with extended application limits in order to provide multiple possibilities for hot regions and data center cooling. The speed control with integrated frequency inverter (FI) over a wide control range provides excellent part load and seasonal efficiency.

CSW with motor 4

Application

// water cooled liquid chillers which also meet the globally most demanding efficiency regulations: the Chinese GB19577:2015

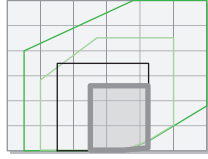

Technical details

- // adaptation to low pressure ratios
 - particularly low friction losses
 - optimised lubrication system
- // motor with low energy consumption
- // economiser (ECO) at full load
- // connection for oil and gas return from flooded evaporator
- // optimised for refrigerants with low pressure, also A2L

Refrigerants

- // R134a // R1234yf
- // R450A // R1234ze(E)
- // R513A // R515B

CSW

Applications

- // applications with low condensing temperatures
- // systems with flooded evaporator
- // water cooled liquid chillers
- // air cooled liquid chillers in cooler countries
- // medium temperature process cooling

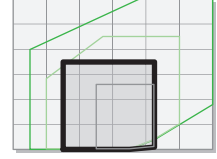

Technical details

- // optimised for low pressure ratios
- // economiser (ECO) at full load
- // connection for oil and gas return
- // 2 motor sizes can be selected
- // extended refrigerant selection, also A2L

Refrigerants

- // R134a // R1234ze(E)
- // R450A // R515B
- // R513A // R407C with CSW65 to CSW95
- // R1234yf // R22 with CSW65 to CSW95

The CSW capacity range

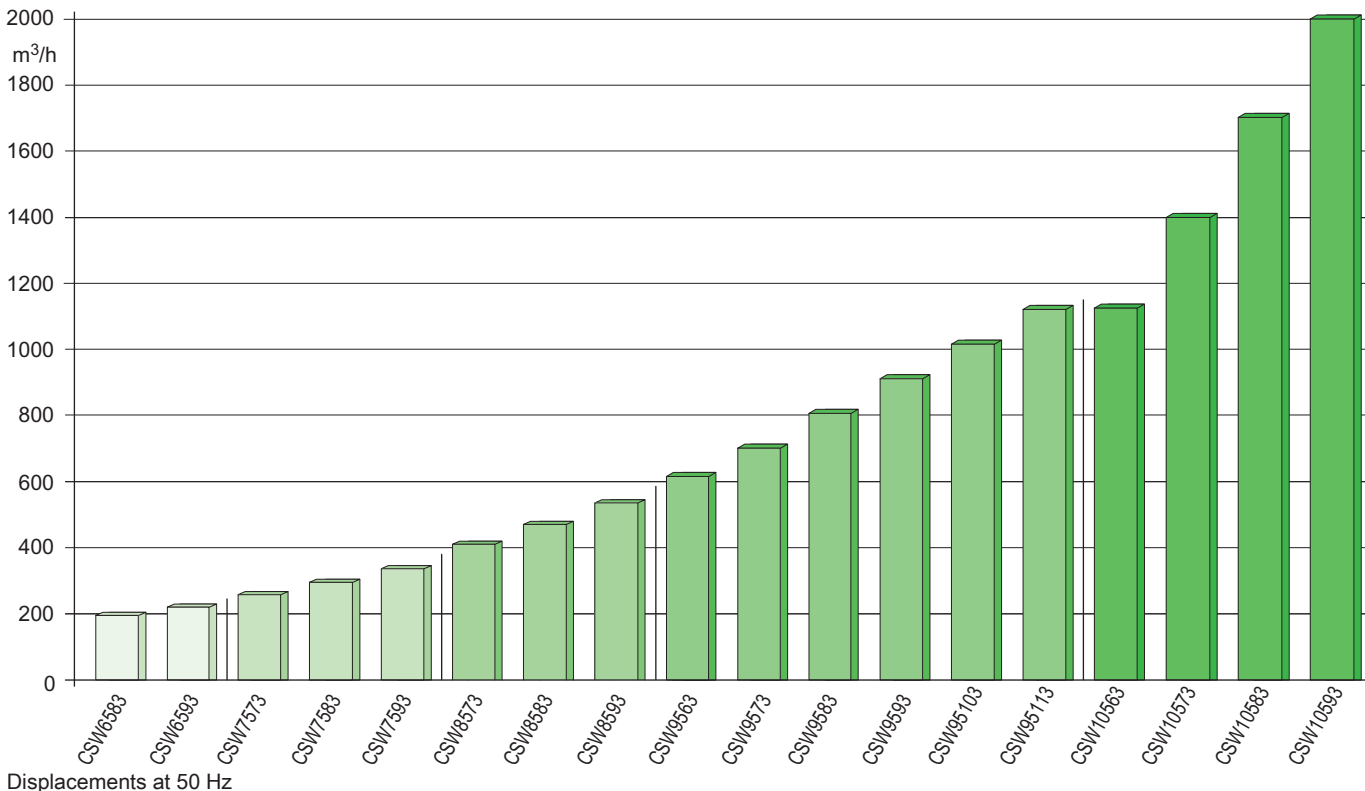

Application limits for CSW

R134a ■ R1234yf ■ R450A ■ R513A

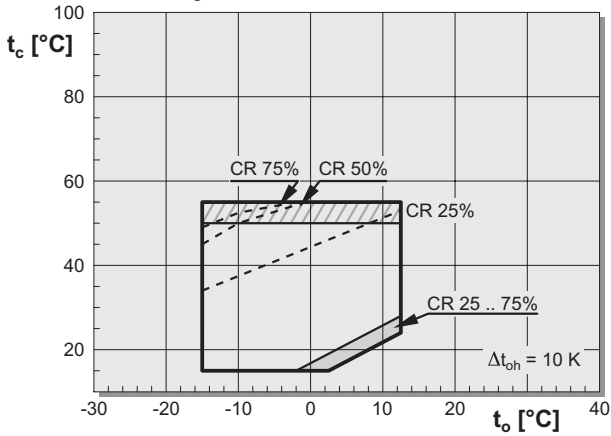

R1234ze(E) ■ R515B

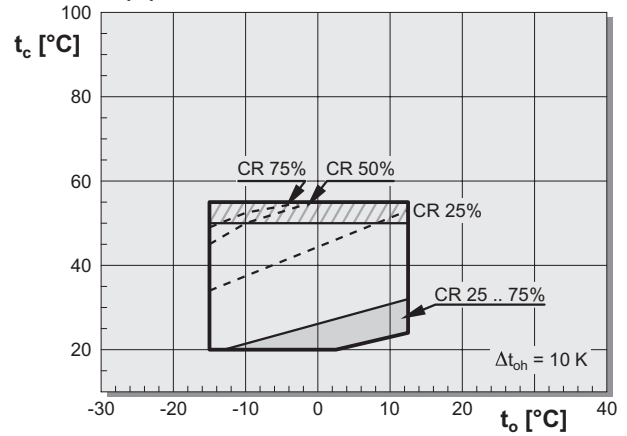

R407C

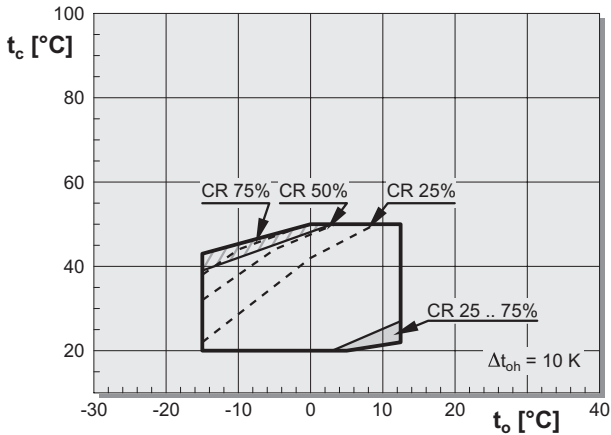

R134a ■ R1234yf ■ R450A ■ R513A Motor 4

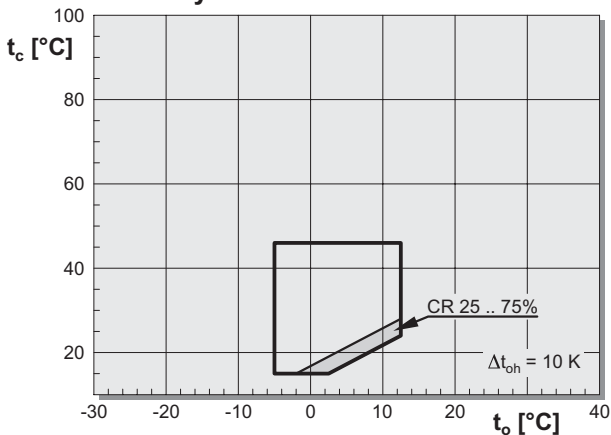

R1234ze(E) ■ R515B Motor 4

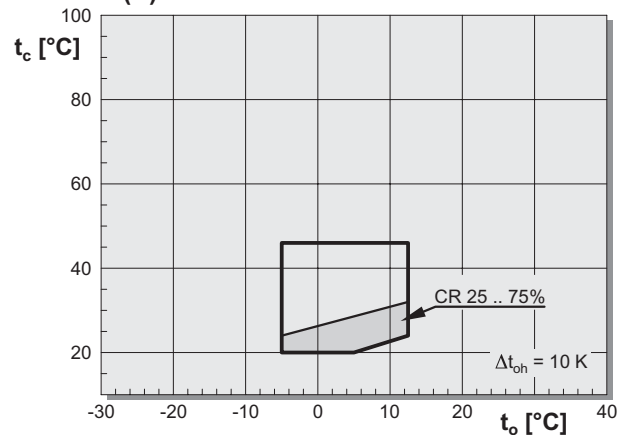

Legend

t_o Evaporation temperature (°C)
 t_c Condensing temperature (°C)
 Δt_{oh} Suction gas superheat (K)

- Suction gas superheat max. 5 K
- Capacity control CR 25% .. max. CR 75%

Capacity control (CR)

Thermal limits for capacity control (CR) depend on compressor model. The maximum condensing temperature can be restricted with individual models.

Application limits for economiser operation (ECO)

See BITZER SOFTWARE.

CSW105

The CSW105 series comprises our currently largest series screw compressors: four displacement stages from 1170 to 2000 m³/h at 50 Hz and up to 2400 m³/h at 60 Hz or FI operation.

The exceptional full load and part load efficiency of the compressors enables series production of highly efficient liquid chillers that meet the world's most demanding efficiency requirements:

// EU: 2016/2281 Ecodesign Directive for comfort air conditioning liquid chillers

// China: GB19577:2024
Minimum allowable values of energy efficiency and energy efficiency grades for water chillers

Applications

- 1 highly energy-efficient water cooled liquid chillers
 - with only one or with several compressors
 - with the refrigerants R134a or R513A
 - at typical operating conditions for water cooled liquid chillers
- 2 highly energy-efficient high power air cooled liquid chillers
 - with the refrigerants R1234ze(E) and R515B
 - The CSW105 also allows high performance with R1234ze(E) or R515B, although their volumetric cooling capacity is only 75% of the cooling capacity of R134a or R513A.
- 3 heat pumps for energy recovery
 - in reversible chillers for combined cooling and heating
 - with the refrigerants R1234ze(E) and R515B
 - Comfort heating or process heat pump (COP_{heat} up to 5.49)

CSW10593-400Y at 60 Hz or FI operation

Refrigerant	t _o	t _c	Δt _u	Δt _{oh}	Q _o	COP
① R134a/R513A	6°C	36°C	3 K	2 K	1.8 MW	6.41
② R1234ze(E)/R515B	4.5°C	47°C	3 K	2 K	1.1 MW	4.22
③ R1234ze(E)/R515B	25°C	65°C	3 K	2 K	Q _c 2.4 MW	COP _{heat} 5.49

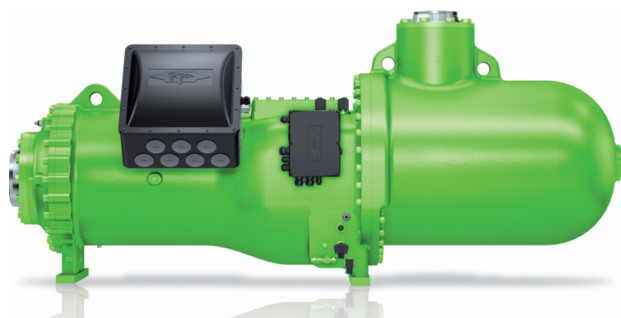

Technical details

- // double-slider technology
- // IQ module with automatic V_i adaption
 - operation at optimum V_i
 - avoids losses due to under- or over-compression
 - integrated mechanical capacity control from 25 to 100%, steplessly controlled by the IQ module
- // large-volume built-in motor
- // highly optimised profile geometry

Application limits for CSW105

R134a ■ R1234yf ■ R450A ■ R513A

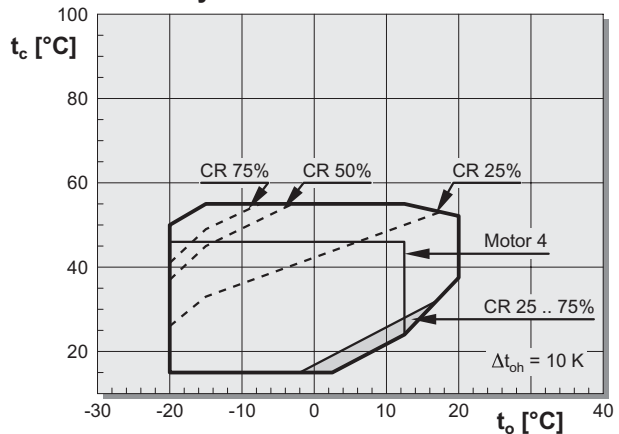

R1234ze(E) ■ R515B

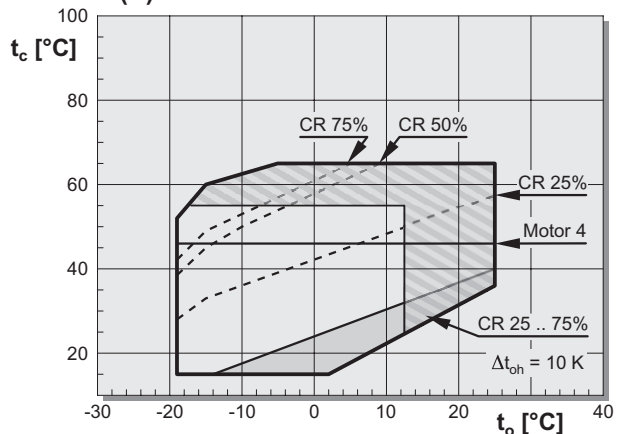

Legend

- t_o Evaporation temperature (°C)
- t_c Condensing temperature (°C)
- Δt_{oh} Suction gas superheat (K)

- Capacity control CR 25% .. max. CR 75%
- ▨ BSE170 required

Capacity control (CR)

Thermal limits for capacity control (CR) depend on compressor model. The maximum condensing temperature can be restricted with individual models.

Capacity control (CR), V_i and frequency inverter (FI) operation

Capacity control (CR)

- // efficient capacity control by shifting the suction port
- // CSH6 to CSH9 and CSW6 to CSW9
easy activation via flanged-on solenoid valves
 - stepless
(CR100 \leftrightarrow CR25%)
 - multistep in three steps
(CR100% \leftrightarrow CR75% \leftrightarrow CR50% \leftrightarrow CR25%)
 - alternative operation mode due to different control logics – without modifying the compressor
- // CSW105
intelligent compressor module with extended protection concept and slider operation
 - efficient stepless capacity and V_i control due to optimised slider concept
(CR100% \leftrightarrow CR25%)
 - automatic V_i control
 - high efficiency in extended application limits

Automatic start unloading (SU)

- // start-up from lowest load conditions

Operation with external frequency inverter (FI)

- // for complete CS. series
- // with all appropriately sized FI models, vendor independent
- // standard control range 25 .. 60 Hz
- // extended control range also by combining FI+CR in coordination with BITZER
- // The entire application limits can only be realised when operating at 60 Hz with FI on the 400 V-50 Hz mains if the special motor for 380 V and 60 Hz nominal voltage is selected. This is motor code 35D
- // Further information see Technical Information ST-420 (online documentation).

CSH.6

Applications

- // air cooled liquid chillers in temperate and cold climate zones
- // data center cooling
- // typical heat pump operation of liquid chillers for air conditioning
- // liquid chillers with high efficiency requirements

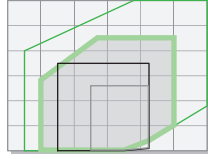

Technical details

- // economiser (ECO) at full load
- // optimised for refrigerants with low pressure, also A2L

Refrigerants

- // R134a // R1234yf
- // R450A // R1234ze(E)
- // R513A // R515B

CSH.5

Applications for CSH.5 with the most powerful motor

- // very broad and flexible application range
- // data center cooling
- // air cooled liquid chillers for air conditioning for all climate zones
- // heat pumps with high condensing temperatures or low evaporation temperatures
- // process cooling

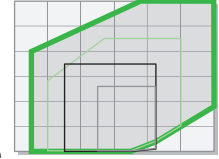

Technical details

- // economiser (ECO) at full and part load
- // liquid injection (LI)
- // oil cooler connection
- // 2 motor sizes can be selected
- // wide refrigerant selection, also A2L

Refrigerants

- // R134a // R407A
- // R450A // R407C
- // R513A // R407F
- // R1234yf // R22
- // R1234ze(E) // R245fa
- // R515B



For the operation in ATEX zone 1 and 2 special ATEX designs of each CSH.5 compressor are available.

The CSH capacity range

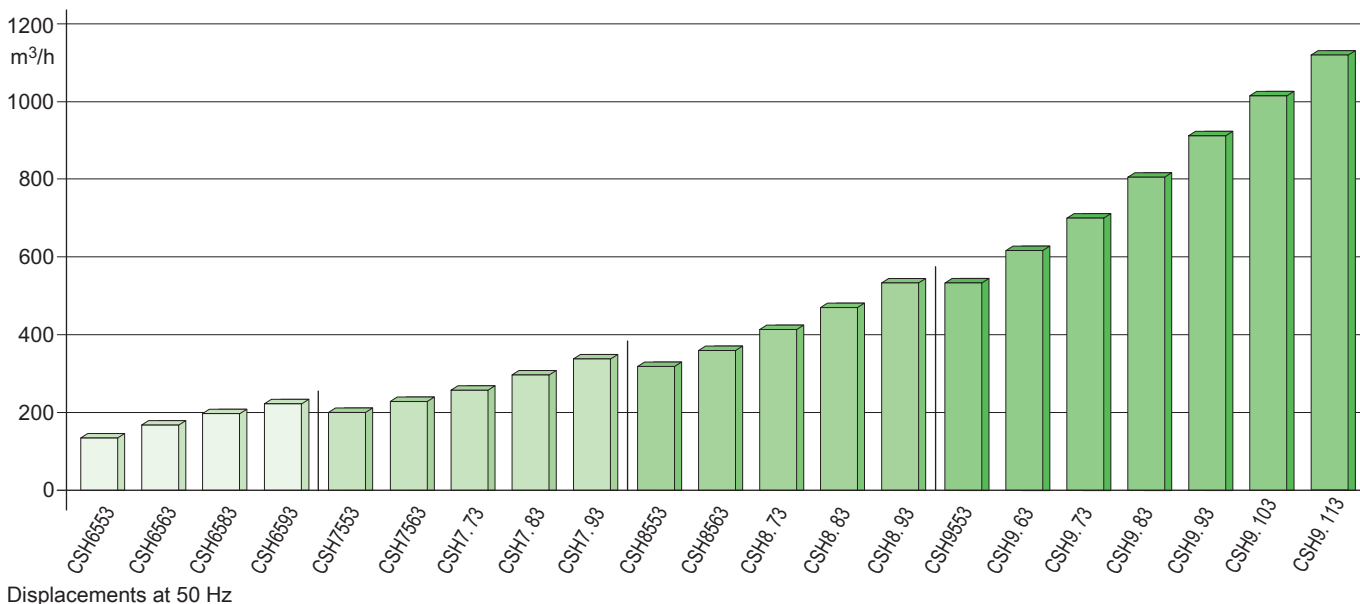

Displacements at 50 Hz

Application limits for CSH

CSH.5: R134a ■ R1234yf ■ R450A ■ R513A

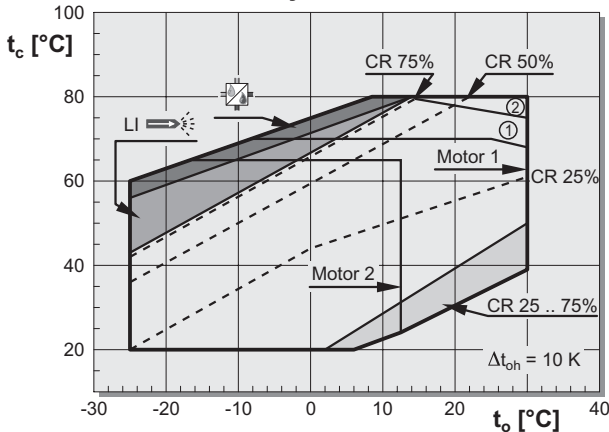

R450A: minimum evaporation temperature: -22°C

CSH.5: R1234ze(E) ■ R515B

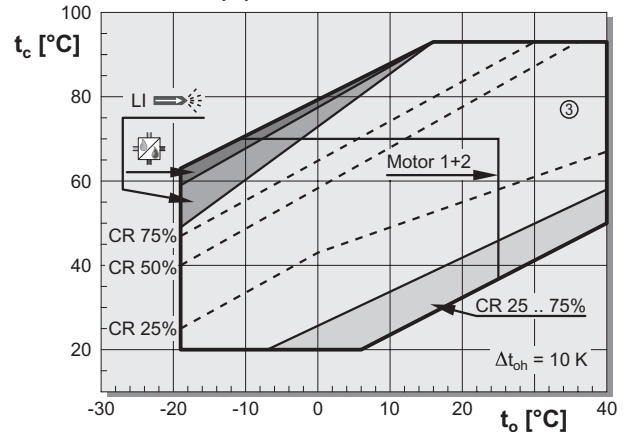

CSH.5: R407C

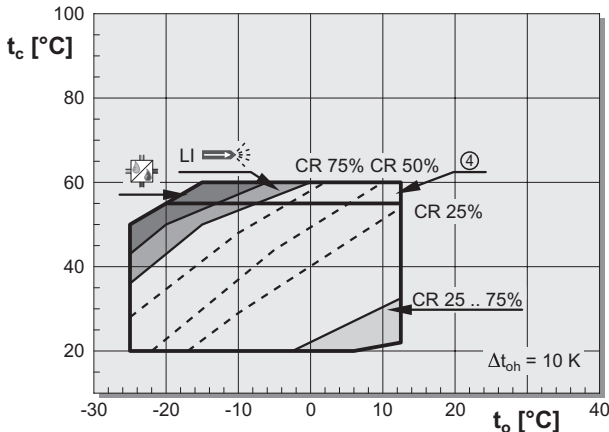

Extended ranges for individual compressors

- ① 400 V network operation at 50 Hz for the compressors CSH6553-50Y, CSH6563-60Y, CSH7553-70Y, CSH7563-80Y, CSH7573-90Y, CSH7583-100Y, CSH8553-110Y, CSH8563-125Y, CSH8573-140Y, CSH8593-180Y, CSH9553-180Y, CSH9563-210Y, CSH9573-240Y and CSH9583-280Y
- ② 400 V network operation at 50 Hz for the compressors ① with R450A only
- ③ CSH7553-70Y, CSH7563-80Y, CSH7573-90Y, CSH7583-100Y, CSH8553-110Y, CSH8563-125Y, CSH8573-140Y, CSH8593-180Y, CSH9553-180Y, CSH9563-210Y, CSH9573-240Y and CSH9583-280Y
For operation above 70°C condensing temperature the compressor protection device SE-i1 is required.
- ④ Maximum condensing temperature 55°C for CSH8583, CSH8593, CSH9593 and CSH95103

CSH.6: R134a ■ R1234yf ■ R450A ■ R513A

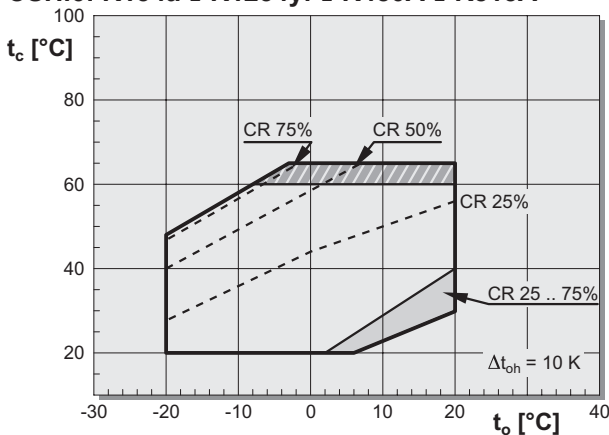

CSH.6: R1234ze(E) ■ R515B

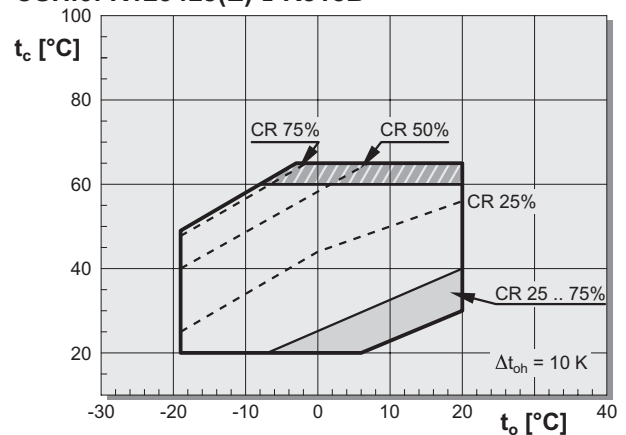

Legend

t_o Evaporation temperature (°C)
 t_c Condensing temperature (°C)
 Δt_{oh} Suction gas superheat (K)

■ Liquid injection or external oil cooling required.
 For part load operation the respective application limits (CR 75%, CR 50% and CR 25%) can be lifted by 5 K condensing temperature through liquid injection (up to the full load limits).

■ External oil cooling required
 ■ Capacity control CR 25% .. max. CR 75%
 ■ Operation only possible with BSE170

Further explanations see next page.

Refrigerants with very low global warming potential

For the environmentally friendly refrigerants R290 propane and R600a isobutane, both classified flammable A3 according to ISO817, special compressor models CSHP.. are available.

The unsaturated partly fluorinated hydrocarbons (HFO) R1234yf and R1234ze(E), two variants of tetrafluoropropene, have very low GWP values, too. They can be used as pure substances or as components of blends – see also the application limits. R1234yf and R1234ze(E) are classified as flammable in A2L.

For flammable refrigerants, a risk assessment for the system has to be made reflecting the flammability. The system must be constructed in accordance with national or local regulations.

If the risk assessment classifies the installation area as an explosion protection zone, the special explosion-proof compressor models CSHP.5..X2P, CSHP.5..X2Z, CSHP.5EXP or CSH.5..EXY are to be used.

Further information on the refrigerants can be found in the Refrigerant Report Online Edition A-501.

Ignition sources and enhanced tightness

The products, that are not special explosion-proof, are evaluated to be without ignition sources for the allowed refrigerants under normal operation without failures, based on IEC60335-2-40:2022 clauses 22.116 and 22.117. The products have enhanced tightness according to EN1127-1. This classification means, that no ATEX zone has to be assumed around the product in the case of flammable gases inside the product. For details please contact BITZER..

Thermal limits:

Thermal limits for capacity control (CR) and additional cooling (liquid injection and external oil cooling) depend on compressor model. The maximum condensing temperature can be restricted with individual models. Individual application limits see BITZER SOFTWARE.

Application limits for economiser operation (ECO)

See BITZER SOFTWARE.

Extended application limits

In the BITZER SOFTWARE not all extended application limits are available. Performance data in these ranges upon request.

Application limits for special explosion-proof design

See Operating Instructions SB-179.

CS PRO

Compressors for natural hydrocarbon refrigerants.

Application limits for CSHP

R290

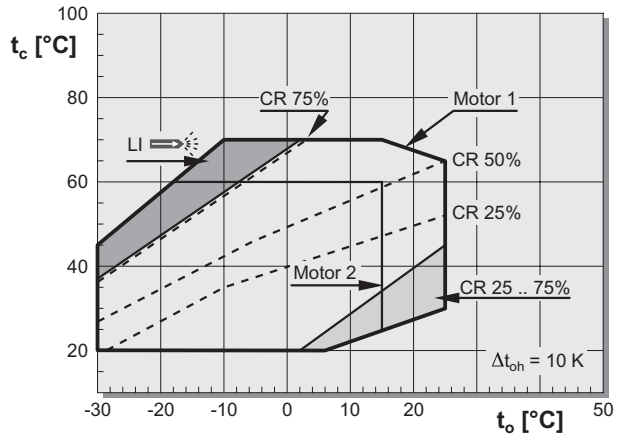

R600a

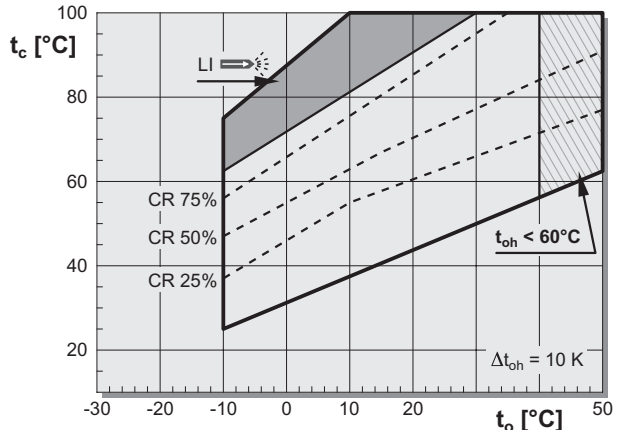

Legend

t_o Evaporation temperature (°C)
 t_c Condensing temperature (°C)
 Δt_{oh} Suction gas superheat (K)

- Liquid injection or external oil cooling may become necessary
- Capacity control CR 25% .. max. CR 75%
- Suction gas temperature less than 60°C

CS PRO: CSHP.6

Applications

- // liquid chillers with high efficiency requirements
- // switchable liquid chillers ↔ heat pumps with water supply up to 65°C
- // data center cooling

Technical details

- // economiser (ECO) at full load

Refrigerant

- // R290 (propane)

CS PRO: CSHP.5

Applications

- // very broad and flexible application range
- // process cooling
- // heat pumps with water supply up to 65°C with R290, propane up to 95°C with R600a, isobutane

Technical details

- // economiser (ECO) at full and part load
- // liquid injection (LI)
- // oil cooler connection
- // 2 motor sizes can be selected

Refrigerants

- // R290 (propane)
- // R600a (isobutane)

The CS PRO capacity range

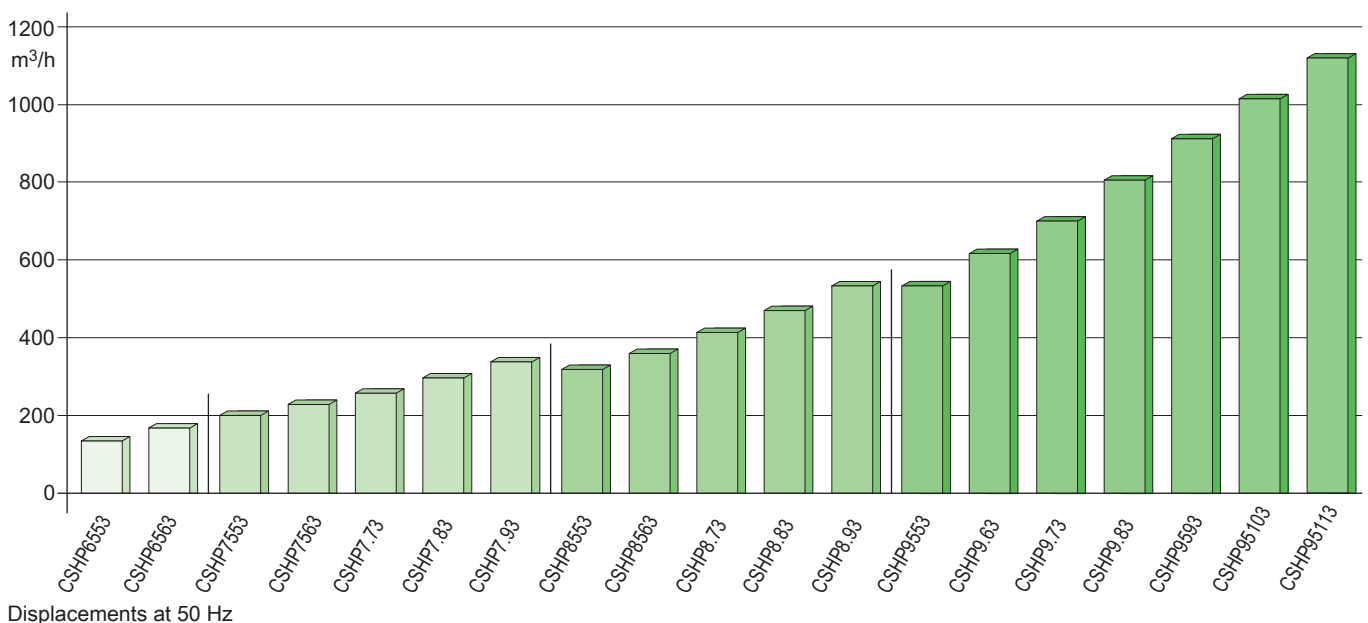

CSVH and CSVW

Semi-hermetic compact screw compressors with integrated frequency inverter (FI)

The CSV. compressor series significantly simplifies the installation and stable operation of high efficient variable speed controlled compressors significantly by a pre-wired package with integrated FI, peripheral devices and sensors for compressor protection and monitoring.



FREQUENCY
INVERTER

The highlights

- // Energy efficient
 - automatic V_i control
 - high efficiency rotor profiles: broad cross sections for high volume flow
 - 3rd generation internal oil management
 - infinite capacity modulation by FI
- // Compact and low weight
 - short length
 - low weight
 - integrated FI
 - low weight per capacity

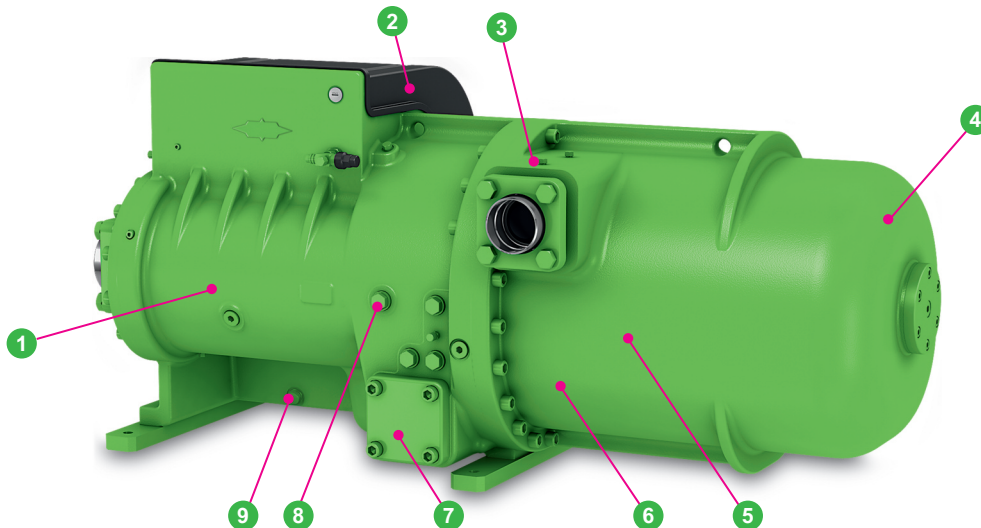

- 1 Special motors for high speed FI operation
- 2 Integrated FI, specially designed and refrigerant cooled
 - // Enhanced operation monitoring and protection functions
 - // Modbus communication to system controller
- 3 Integrated check valve
- 4 3-stage oil separator, designed for low oil carry over rate
- 5 V_i slider, automatically adopting to operating conditions
- 6 Discharge gas pulsation muffler
- 7 Oil filter
- 8 Economiser connection (ECO)
- 9 Gas permeable plug for A2L use

Easy installation

- // FI, motor, sensors and peripheral devices are pre-wired
- // external wiring minimised
 - only 3 wire power connection cables
 - single phase auxiliary voltage
- // Modbus communication

Applications

- // systems with high part load proportion that meet highest efficiency demands
- // compressor for variable base load

CSVW

- optimised for low condensing temperatures:
- // water cooled liquid chillers
 - // systems with flooded evaporator

CSVH

- optimised for large temperature differences between evaporation and condensation:
- // air cooled liquid chillers
 - // process cooling
 - // heat pump applications

Technical details

- // especially designed V_i for the application
- // important design features adapted from CS. developments
- // control range: down to 15% of full load with automatic V_i adaptation
- // increased compressor availability
 - enhanced operation monitoring
 - improved controllability due to a multilevel alarm system
 - user settings for system adaptation / optimisation

Refrigerants

- // R134a // R1234yf (A2L)
- // R450A // R1234ze(E) (A2L)
- // R513A // R515B

The CSVH capacity range

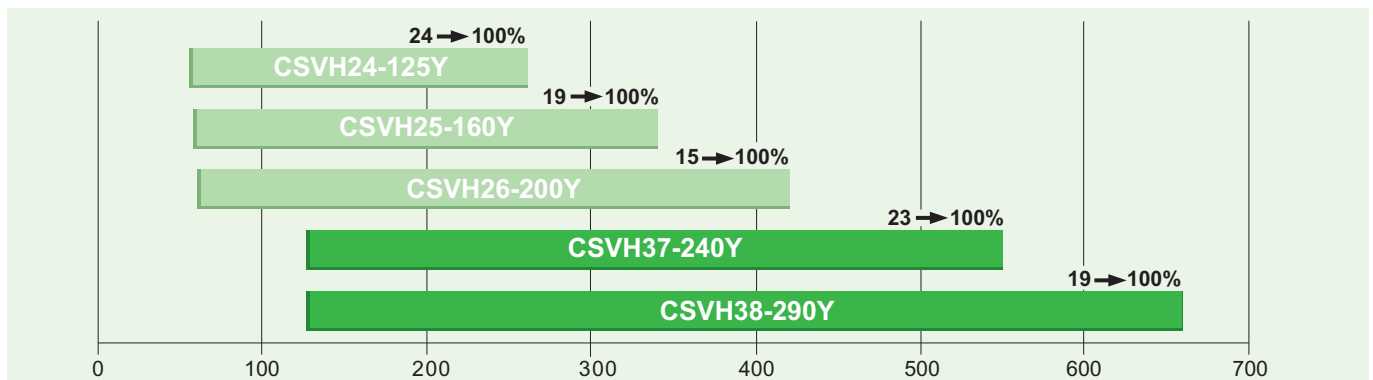

Cooling capacity in kW at typical operating conditions of liquid chillers (to = 5°C) with R134a

Simple handling and serviceability

- // Pre-wired package
 - integrated FI
 - cooling controls for FI
 - V_i slider control valves
 - low and high pressure transmitters
 - oil temperature sensor
 - oil heater
 - oil level monitoring
- // Simple serviceability
 - suction gas filter with large surface and fine mesh
 - oil sight glass
 - oil valve for maintenance
 - exchangeable oil filter

Application limits for CSV.

CSVH: R134a ■ R1234yf ■ R450A ■ R513A

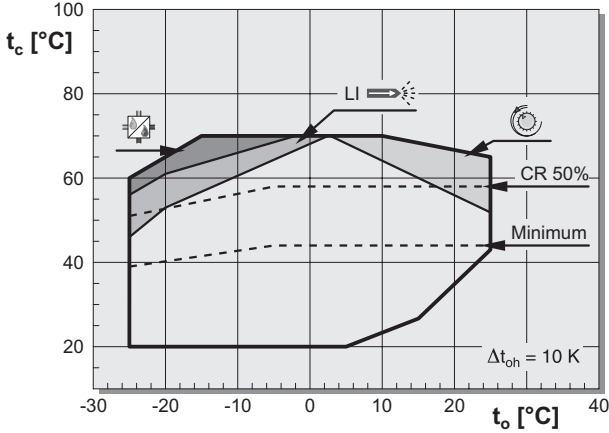

R450A: minimum evaporation temperature: -22°C

CSVH: R1234ze(E) ■ R515B

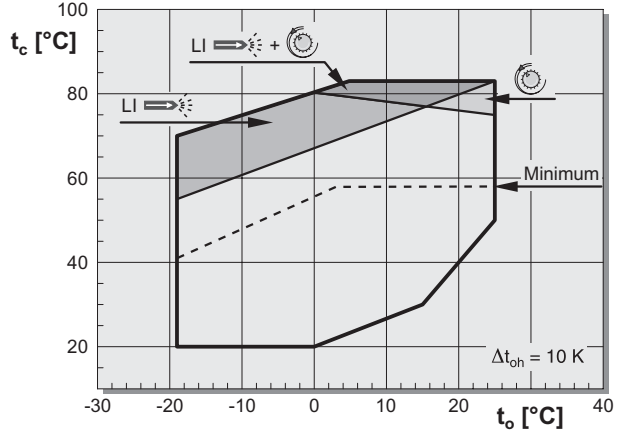

CSVH2..MY: R134a ■ R1234yf ■ R513A

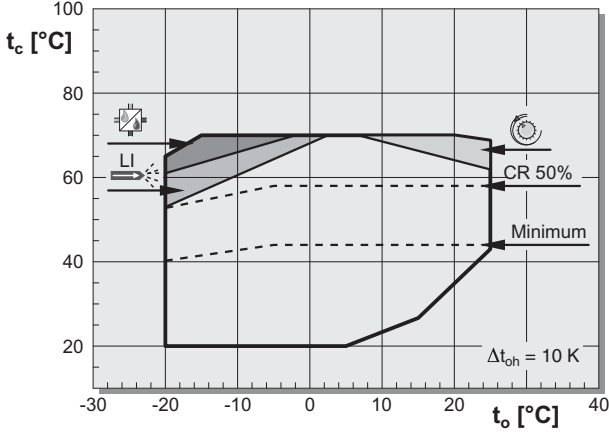

CSVH2 with permanent magnet motor

CSVW: R134a ■ R1234yf ■ R450A ■ R513A

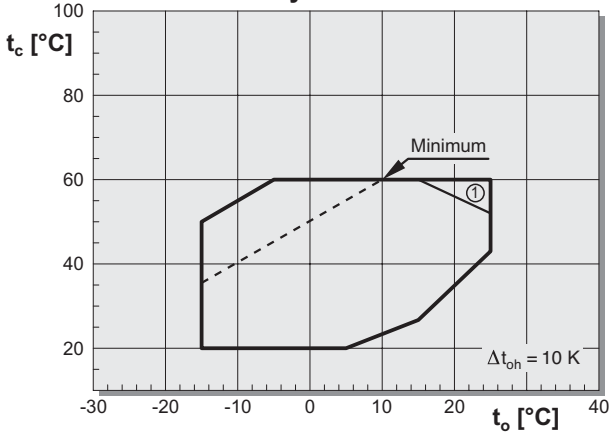

CSVW: R1234ze(E)

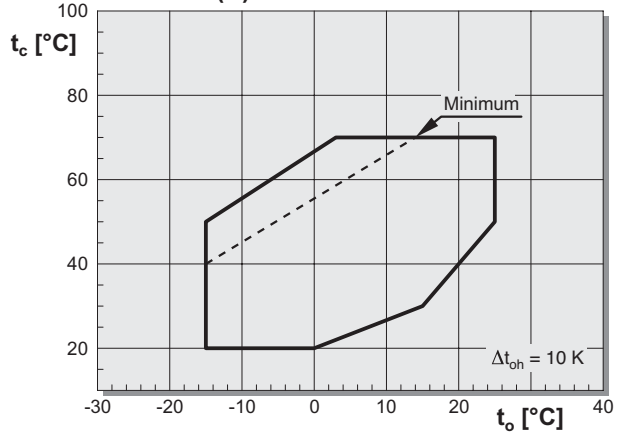

Legend

t_o Evaporation temperature (°C)
 t_c Condensing temperature (°C)
 Δt_{oh} Suction gas superheat (K)

- Liquid injection or external oil cooling required
- External oil cooling required
- Speed is automatically adjusted if required

Extended ranges for individual compressors

① Operation in this range only possible with CSVW2.

Thermal limits

CSVH: Thermal limits for capacity control (CR) and additional cooling (liquid injection and external oil cooling) can be higher depending on compressor.

CSVW: In part load the maximum condensing temperature is restricted, depending on compressor. Individual application limits see BITZER SOFTWARE.

Application limits for economiser operation (ECO)

See BITZER SOFTWARE.

CSV.: Tuned-in electrics

Motor

- // designed for high speed FI operation
- // extra large speed range – up to more than 1 : 6
- // suction gas cooled
- // temperature monitored by FI control

Frequency inverter (FI)

- // designed specifically for CSV. series
 - small size
 - cooling plate with evaporating refrigerant
- // all components designed for full lifetime – no special maintenance required
- // integrated monitoring with warning and alarm functions
- // ready wired monitoring and operating components
- // wide voltage range: nominal 380 .. 480 V at 50 and 60 Hz
- // Bluetooth communication with FI control
- // Modbus communication port to system controller
- // STO function: safe torque off, motor contactor is not necessary
- // softstart function – continuous current rise to operating current without usual inrush peak

Softstart characteristics

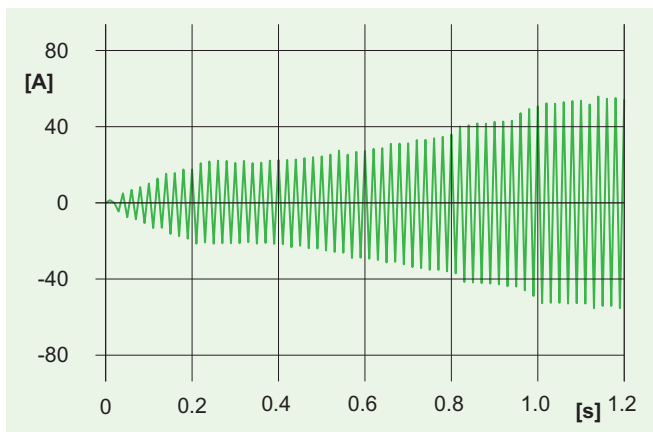

Current consumption at compressor start

Permanent magnet motor

- // synchronous motor with high efficiency due to permanent magnets
- // rotor is synchronous with the rotating field
- // wide working range, with high efficiency
- // significantly more efficient than the standard motor – especially at part load

Energy efficiency improvement

The permanent magnet motor is designed for the same full load conditions as the standard motor. Therefore, the electrical values on page 28 are almost identical for the two compressor motorisations. Nevertheless, a compressor with permanent magnet motor is more efficient than the standard asynchronous motor in all load conditions, especially in part load. Depending on the compressor, the SEERon value is up to 5.4% higher.

An "M" at the end of the type designation is the coding for compressors with permanent magnet motor.

CSVH24-125(M)Y	4,8%
CSVH25-160(M)Y	5,1%
CSVH26-200(M)Y	5,4%

Improvement of the SEERon, which is the seasonal energy efficiency according to EU 2016/2281, in direct comparison between liquid chillers each with one compressor either with permanent magnet motor e. g. CSVH26-200MY or with standard motor e. g. CSVH26-200Y.

Optional electrical accessories

- // Line reactor
- // Radio frequency interference filter
- // BEST Interface Converter

Line reactor (L1)

For operation of the compressor, a line reactor is absolutely necessary. It reduces the harmonics which are transmitted to the power supply system by the FI.

Only with a matching line reactor, the CSV. compressors comply with the category C3 according to EN61800-3:2005. In this case CSV. compressor may be operated at an industrial low voltage network that is separated from the public power supply network by means of a transformer (industrial environment).

RFI filter (Z1)

An RFI filter eliminates the interference waves in the radio frequency range which are emitted by the FI to the power network and which can be radiated by the electric lines. The emitted interference of the FI can be reduced using a line reactor and an RFI filter to such an extent that the compressor can be installed also in residential areas. In this constellation the CSV. compressor has the category C2 according to EN61800-3:2005.

Detailed description see Technical Information ST-160.

Connection of power voltage

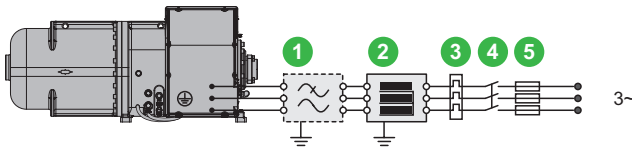

- ① RFI filter
Not necessary in all cases.
- ② line reactor
- ③ overload protective device
- ④ compressor contactor
Not necessary if STO is used.
- ⑤ compressor fuse

Accessories for CSH, CSW, CSVH and CSVW

Sound insulation hoods

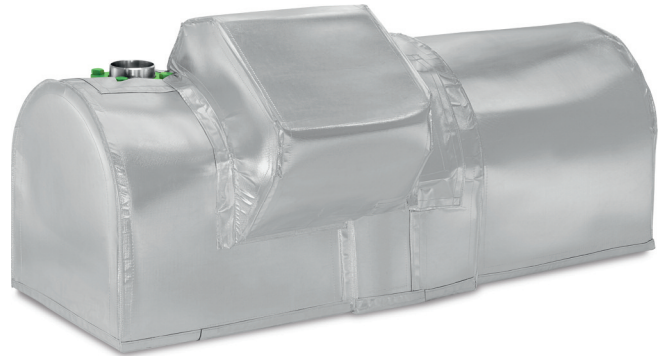

- // Efficient sound reduction
 - depending on compressor model and mounting situation, up to 12 dB(A)
 - effective over the whole frequency range
- // Easy to mount and to retrofit
 - flexible material
 - fastening with Velcro straps
 - adapted for every housing series
- // Easy to maintain
 - Easy access to the oil sight glass and to all connections.
 - Pipes and cables can be put through at any place.
- // Tested and proven combination of sound absorbing materials
 - robust
 - water-repellent
 - difficult to ignite (class B1 according to DIN4102)
 - released only for refrigerants of safety group A1
- // Application range
 - Within all application limits
 - Depending on operating point, the thermal limits for capacity control or additional cooling may be at lower condensing temperatures.
 - For an outdoor installation a weather protective housing or a roofing is required.

Series	Sound reduction	Weight	Part number
CSH6/CSW6	.. 10 dB(A)	40 kg	37790705
CSH7/CSW7	.. 10 dB(A)	45 kg	37790704
CSH8/CSW8	.. 10 dB(A)	50 kg	37790702
CSH9/CSW9	.. 8 dB(A)	60 kg	37790701
CSVH2/CSVW2	.. 12 dB(A)	45 kg	37790703
CSVH3/CSVW3	.. 10 dB(A)	50 kg	37790801
CSVH3/CSVW3 Sectional sound insulation hood	.. 4 dB(A)	30 kg	37790802

Mounting space

At the highest point and at the sides the sound insulation hood is approximately 40 mm thick.

The hood encloses the whole compressor. For the mounting, a free space of about 100 mm is recommended. The sound insulation hood can be retrofitted even in confined space conditions and if the pipes are already connected.

Sectional sound insulation hood

A sectional sound insulation hood is available for the CSVH3 and CSVW3. It covers the motor, the FI and the compressor side but not the oil separator side.



The accessories at a glance

For the CS. and CSV. series, BITZER offers a comprehensive equipment and accessory range.

Equipment and accessories	CSH.5	CSH.6	CSH2T	CSW	CSW105	CSVH	CSVW
suction gas bushing	✓	✓	✓	✓	✓	✓	✓
suction gas valve ①	0	0	0	0	0	0	0
discharge gas bushing	✓	✓	✓	✓	✓	✓	✓
discharge gas valve ①	0	0	0	0	0	0	0
check valve discharge gas outlet	✓	✓	✓	✓	✓	✓	✓
muffler for discharge gas line	0	0	0	0		0	0
compressor protection device SE-E4	✓	✓		✓			
compressor protection device SE-E5	0	0		0			
compressor protection device SE-i1 ②	0	0	✓	0			
compressor module CM-SW-01					✓		
FI						✓	✓
BEST interface converter	0	0	0	0	0	0	0
line reactor						0	0
RFI filter						0	0
coils for capacity control ③	✓	✓	✓	✓	✓		
coils for V _r -control ③							
switch for minimum oil level	0	0	✓	0	✓	✓	✓
switch for maximum oil level	0	0	0	0	0	0	0
economiser valve ④	0	0	0	0 ⑤	0	0	0
adaptor for liquid injection (LI)	0		0			0	
adaptor for oil cooling	0		0			0	
adaptor for oil and gas return				0	0		0
oil heater ⑥	✓	✓	✓	✓	✓	✓	✓
terminal box cover heater	0	0		0			
vibration dampers	0	0	0	0	0	0	0
bridges for direct-on-line start ⑦	S	0		0			
sound insulation hood	0	0		0	0	0	0
sectional sound insulation hood ⑧							0
oil charge	✓	✓	✓	✓	✓	✓	✓
CE	S	S	S	S	S	S	S
⑨UL	0			⑨		0	0

- ✓ mounted equipment, included in standard scope of delivery
- S included in standard scope of delivery
- 0 optional accessory
- ① up to DN125
- ② required with operation above 70°C condensing temperature
- ③ for 230 V 50/60 Hz
- ④ CSH and CSVH: with pulsation muffler
- ⑤ not with motor 2 and R22 or R407C
- ⑥ 200 .. 230 V
- ⑦ not for CS.95103 and CS.95113
- ⑧ CSV.3 only
- ⑨ upon request

Refrigeration oils

The miscibility of the refrigerant in the oil and the change of lubricity at different temperatures are significant for the selection of the suitable refrigeration compressor oil for the respective application.

Series	Standard	Alternative with R22	CSHP
CSH.5 Motor 1	BSE170	B320SH	B-PAG220
CSH.5 Motor 2	BSE170		B-PAG220
CSH.6	BSE170L	BSE170	B-PAG220
CSH2T	B-CE500		
CSW Motor 1	BSE170L	BSE170	B320SH
CSW Motor 2	BSE170L	BSE170	
CSW Motor 4	BSE55	BSE170L	
CSVH	BSE170		
CSVW	BSE170L		

The alternative oil is predominantly designated for applications with higher temperatures.

Oil charge code

Final letter in the model designation

// Y: BSE oils and B-CE500

// P: SHC230 for existing systems

// Z: B-PAG220

// without final letter: B320SH

Oil heaters

ensures the lubricity of the oil even after long standstill periods. It prevents increased refrigerant dilution in the oil and therefore a reduction of viscosity. The oil heater must be used during standstill in case of

// outdoor installation of the compressor

// long shut-off periods

// high refrigerant charge

// risk of refrigerant condensation into the compressor

The CM-SW-01 of CSW105 and the FI control of the CSV. series switches the oil heater on and off if required.

The heating capacity depends on the compressor series:

// CSH65 and CSW65: 200 W

// CSH75, CSH76 and CSW75: 200 W

// CSH85, CSH86 and CSW85: 300 W

// CSH95, CSH96, CSH2T95 and CSW95: 300 W

// CSW105: 300 W

// CSVH2 and CSVW2: 200 W

// CSVH3 and CSVW3: 300 W

Oil level monitoring OLC-D1-S

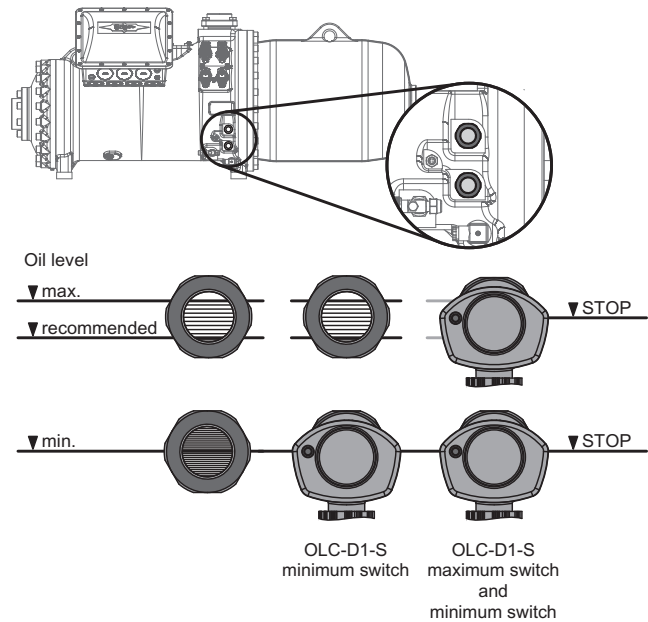

For all compressor types, the minimum and maximum oil level can be monitored electronically. Upon request, the prism unit of the sensor is pre-equipped ex-works. For CSW105 and the CSV. series, the minimum switch is fully electrically connected as standard. For the CSV. series, this is also possible for the maximum switch upon request.

Approvals

BITZER offers ex-works approvals that stand for high quality of the compressors and the manufacturing processes. The respective approval of a legal area naturally includes all design and manufacturing-related legal acts of the respective legal area.

// CE: EU area and United Kingdom

// UL/CSA: USA/Canada and Saudi Arabia

The basic construction of the compressors is designed for the conditions of the CE legal area. Any other product marking may require a special design or equipment and must be known when the order is received. The respective compressor is individually marked. UL availability of the individual compressor series see page 17.

Special approvals

// BV (Bureau Veritas)

// DNV (Det Norske Veritas)

// LR (Lloyds Register of Shipping)

// RMRS (Russian Maritime Register of Shipping)

// further approvals upon request

BITZER works with a wide variety of international certification bodies, in particular ship classification societies. These approvals usually require an inspection of the compressor at the factory by a representative of the certifying body. The desired special approval must therefore be known at the latest when the order is received. Subsequent approval confirmations are not possible.

Special type approval certificates are summarised in the online document AU-100.

Communication with system controller

// via RS485 Modbus RTU

// early warning system reports critical system conditions

// warning levels communication close to application limits enables corrective measures by system controller

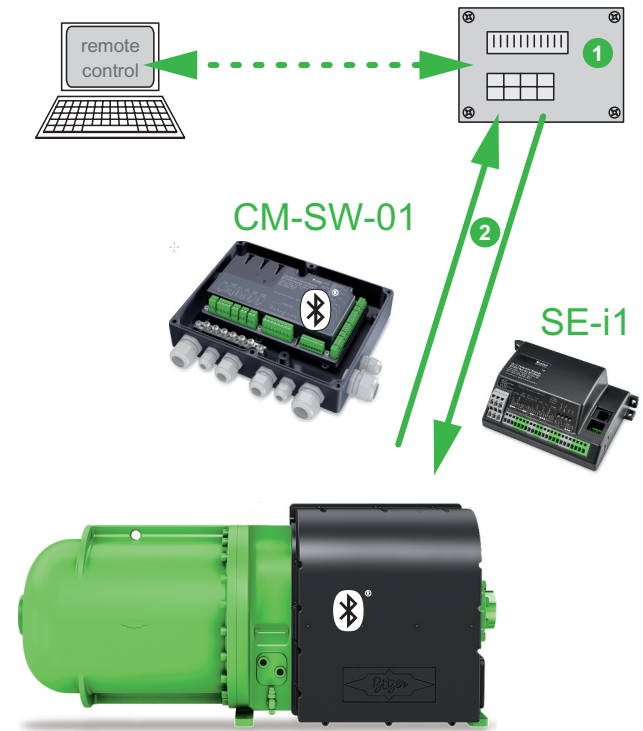

1 superior system controller

2 RS485 Modbus RTU and optional remote control

Intelligent compressor control improves system efficiency.

Compressor monitoring and communication

Compressor protection	SE-E4	SE-E5	SE-i1	CM-SW FU-01	FU CSV.
suitable for	CS.6	CS.6	CS.6	CS.105	CSV.
or	CS.7	CS.7	CS.7		
integrated function	CS.8	CS.8	CS.8		
	CS.9	CS.9	CS.9		
motor voltage	200 .. 690 V	200 .. 690 V	200 .. 690 V	200 .. 690 V	
motor frequency	50 / 60 Hz	50 / 60 Hz	50 / 60 Hz	50 / 60 Hz	
allowable ambient temperature	-30 .. +70°C	-30 .. +70°C	-30 .. +60°C	-30 .. +70°C	-20 .. +55°C ^①
thermal motor monitoring	✓	✓	✓	✓	✓
thermal FI monitoring					✓
suitable for FI operation 83 .. 690 V at 20 .. 135 Hz	✓	✓	✓	✓	integrated
start unloading control				✓	✓
capacity control				✓	✓
V _r -control				✓	✓
oil temperature monitoring	✓	✓	✓	✓	✓
minimum oil level monitoring			✓	✓	✓
oil heater control depending on demand				✓	✓
rotation direction monitoring	✓	✓	✓	✓	safe
Phase failure monitoring	✓	✓	✓	✓	safe
monitoring of overvoltage and undervoltage					✓
overcurrent monitoring					✓
restart delay	✓	✓		✓	✓
cycling rate monitoring			✓	✓	✓
application limits monitoring			✓	✓	✓
low pressure cutout			✓	✓	✓
high pressure switch			✓	✓	✓
status LEDs				✓	
data log			✓	✓	✓
warning level communication close to the application limits			✓	✓	✓
Bluetooth communication				✓	✓
BEST/Modbus communication			✓	✓	✓
CE	✓	✓	✓	✓	✓
UL	✓	✓	✓	✓	✓

① Daily average: 40°C

Indicate refrigerant when ordering a CSVH, CSVW, CSW105 or a compressor with SE-i1.



Via PC, all BITZER IQ products may be monitored and configured with the BEST SOFTWARE. With its intuitive user interface it displays a complete operating status overview including data log for easy maintenance and service. This is completely in line with our innovation targets.

Communication

// via BEST interface converter or Bluetooth

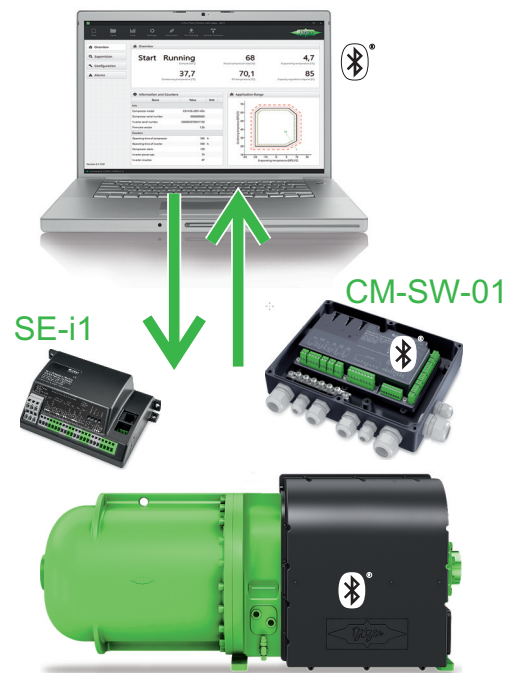

Easy configuration

- // easy device parameterisation
- // storing and installing of device and compressor setups
- // safe and easy firmware update

Reliable online diagnosis

- // display of all connected sensors, e. g. pressure transmitters, temperature sensors, oil level switches, digital and analogue inputs and outputs
- // current operating point within the application limit
- // current capacity control status

Comfortable analysis

- // data log download and visualisation of all operating parameters
- // alarm list with integrated help function for easy maintenance and service
- // prepared for data analysis via the BITZER DIGITAL NETWORK

BITZER DIGITAL NETWORK

The BITZER Digital Network (BDN) provides comprehensive access to your compressor data. It enables remote access and remote diagnostics in real time by connecting to your own refrigeration system.

- // at any time.
- // at any place.
- // well protected.

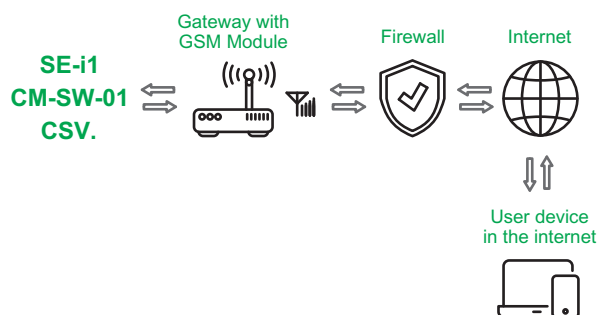

The pre-configured BITZER gateway provides a secure data connection between the compressor and the internet.

All BITZER applications are quickly and easily accessible via the BDN. It connects the user with the entire product knowledge. The BDN makes these innovations possible:

- // easy installation and integration into customer systems
- // preventive maintenance
- // own digital infrastructure
- // saving time
 - when visiting the system
 - in the analysis of operating data
 - in the diagnosis of problems
- // data analysis in high temporal resolution
- // fast troubleshooting
- // notification of problems, e. g. error messages via email

Intelligent compressor protection and remote control

A new generation of intelligent electronics operates, monitors and protects screw compressors beyond the standard requirements and communicates with the superior system controller.

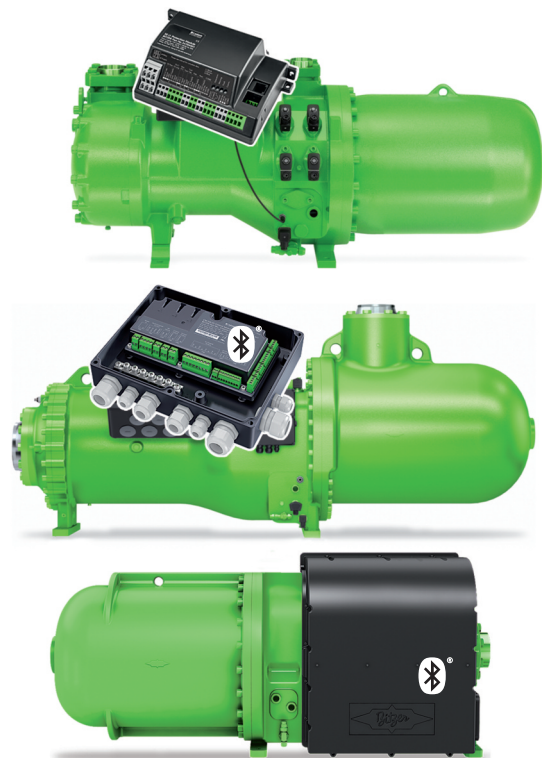

- // SE-i1
 - communicates via: RS485 Modbus RTU, BEST interface converter
 - standard for CSH2T and for CSHP with R600a
 - option for CSH65 to CSH95 and CSH96
 - option for CSW65 to CSW95
- // CM-SW-01 standard in CSW105
 - communicates via: RS485 Modbus RTU, Bluetooth, BEST interface converter
- // CSVH and CSVW, integrated FI
 - communicates via: RS485 Modbus RTU, Bluetooth, BEST interface converter

The internal data logging provides runtime and load statistics and the history of alarm and warning messages. This makes it possible to analyse the system situation at any time.

These BITZER IQ products actively protect the compressor. They switch off the compressor from critical operating conditions. The sensors and actuators of the BITZER IQ products are delivered ex-works factory wired and preconfigured. This enables quick diagnosis, maintenance and remote control.

Application in heat pumps

This field of application is subject to dynamic development.

BITZER offers compressors for a wide range of supply temperatures:

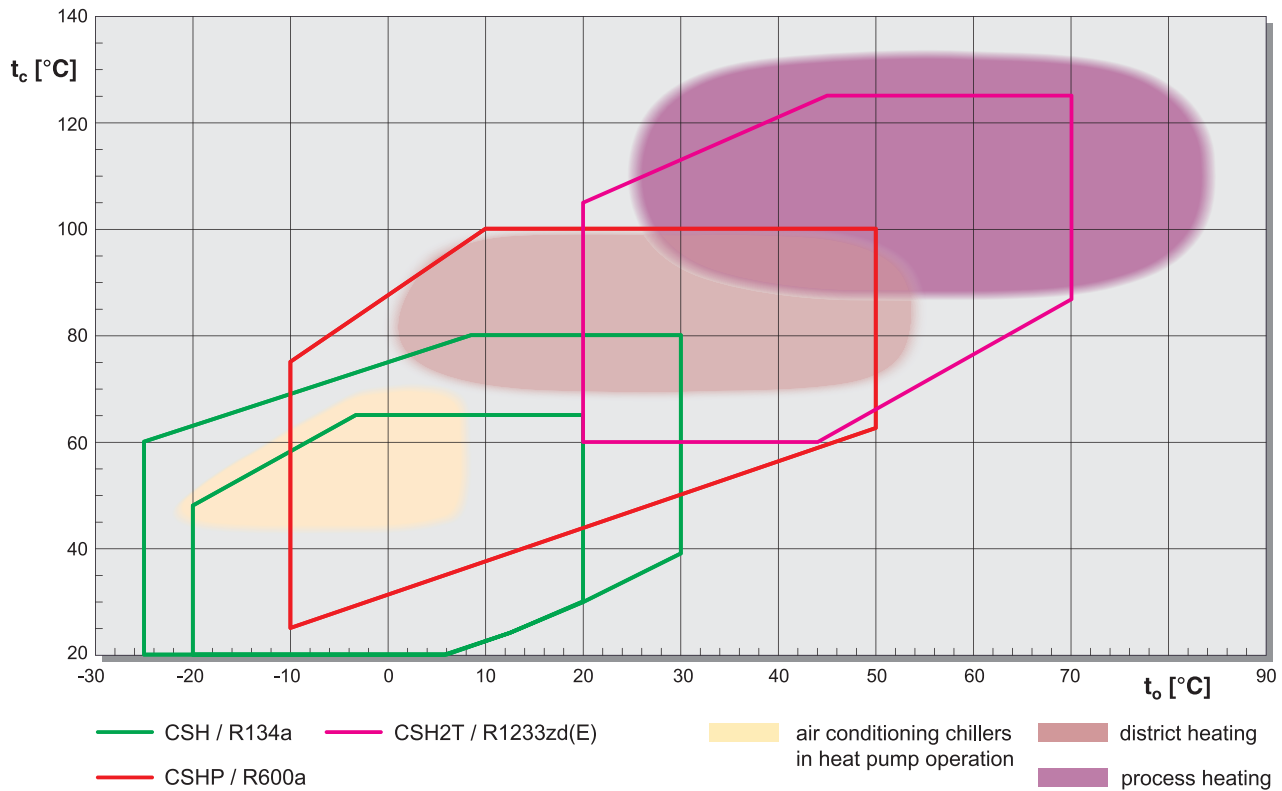

Heat pumps

In case of a heat pump, the focus is on using the hot side of the same process cycle used in refrigeration systems. The design and operation of the condenser, which transfers the heat to a heat sink, for example a district heating network, are optimised here.

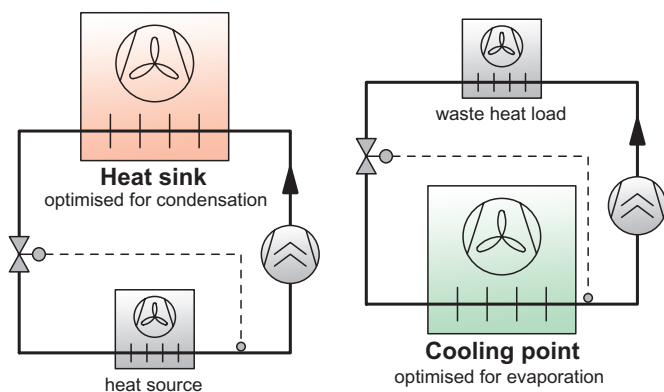

A system can also be operated reversible, switching between cooling in summer and heat pump for heating in winter. In this case, a compromise must be found between the two applications.

Heat pumps are categorised according to their supply temperature, which in the heat pump process is the condensing temperature minus the temperature difference in the condenser.

Supply temperatures between 25 and 65°C can be generated by air conditioning chillers in heat pump operation with the usual refrigerants, e.g. for panel heating or hot water preparation.

The CS PRO compressors are suitable for the temperature range up to 95°C with the naturally occurring refrigerant R600a, isobutane. In this temperature range, the systems are designed as heat pumps and the components have been developed accordingly.

With the CSH2T series, compressors are available for industrial heat pumps that are operated with the refrigerant R1233zd(E). Depending on the condenser design, a supply temperature of up to 120°C can be provided with such a system.

CSH2T

Applications

- // heat pumps for process heating with supply temperature up to 120°C
- // heat source temperature up to more than 70°C

Technical details

- // optimised for high temperatures based on CSH.5
- // economiser (ECO) at full and part load
- // liquid injection (LI)
- // oil cooler connection
- // operation with BITZER frequency inverter between 30 and 60 Hz

Refrigerants

- // R1233zd(E)

Refrigeration compressor oil

- // B-CE500

Application limits

CSH2T: R1233zd(E)

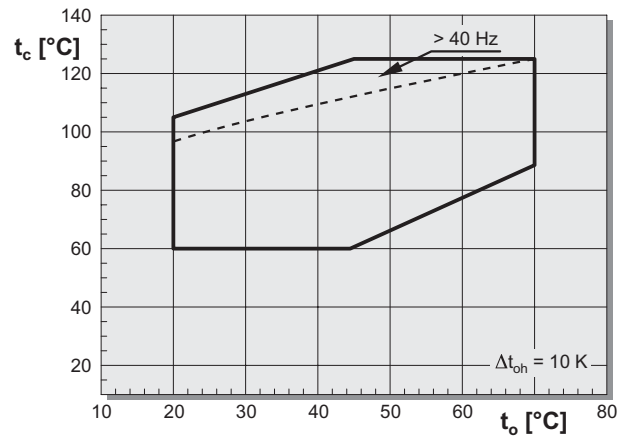

Legend

- t_o Evaporation temperature (°C)
- t_c Condensing temperature (°C)
- Δt_{oh} Suction gas superheat (K)

The CSH2T capacity range

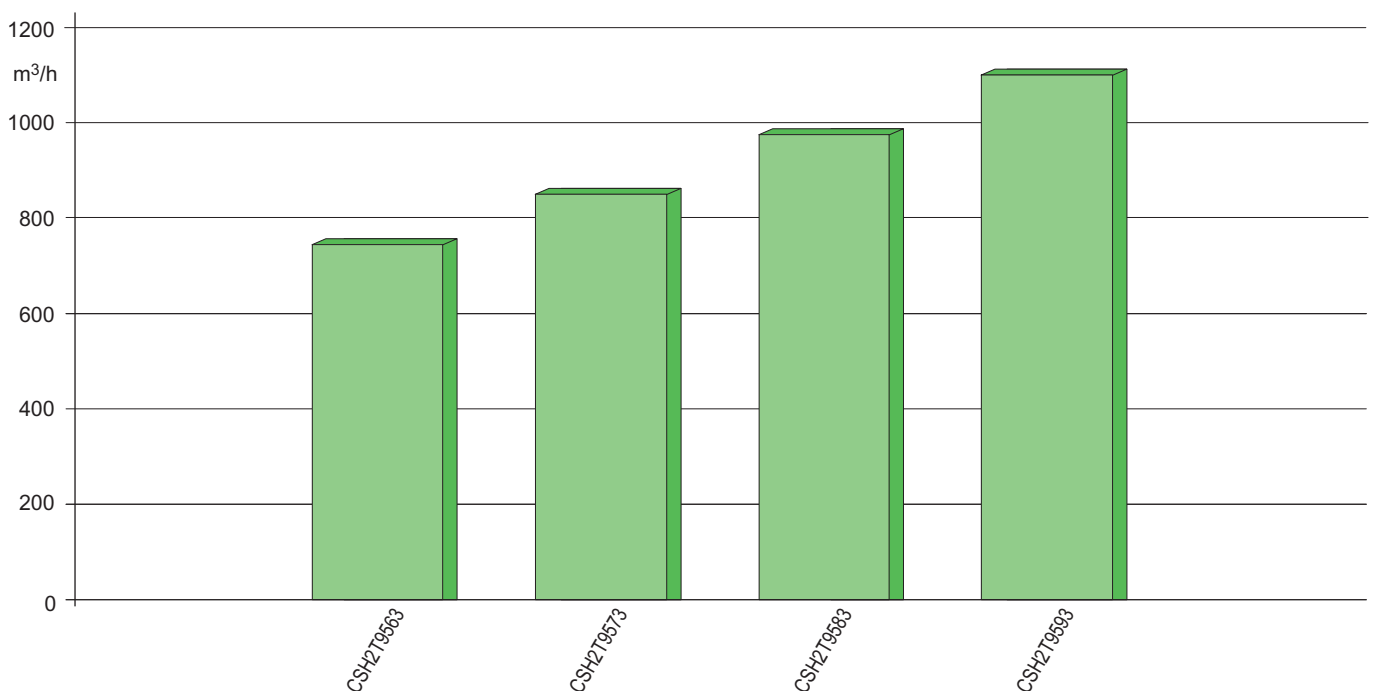

Displacements at 60 Hz



Model designation

CSH and CSW series

Example

CSHP 8573 - 140 Z - 40P

Semi-hermetic compact screw compressor

CSHP 8573 - 140 Z - 40P

Application range

CSHP 8573 - 140 Z - 40P

Series property

P = design for operation with hydrocarbons

2T = design for high temperature applicatio

CSHP 8573 - 140 Z - 40P

Housing size

CSHP 8573 - 140 Z - 40P

Compressor execution

CSHP 8573 - 140 Z - 40P

Displacement

CSHP 8573 - 140 Z - 40P

Compressor execution

CSHP 8573 - 140 Z - 40P

Motor size

CSHP 8573 - 140 Z - 40P

Oil charge:

Y = polyolester oil

P = poly-alpha-olefin

Z = polyalkylene glycol oil

without final letter: B320SH

CSHP 8573 - 140 Z - 40P

Motor code

CSVH and CSVW series

Example

CSVW 25 - 160 M Y - 40M

Semi-hermetic compact screw compressor

CSVW 25 - 160 M Y - 40M

Speed controlled

CSVW 25 - 160 M Y - 40M

Application range

CSVW 25 - 160 M Y - 40M

Housing size

CSVW 25 - 160 M Y - 40M

Size of frequency inverter

CSVW 25 - 160 M Y - 40M

Motor size

CSVW 25 - 160 M Y - 40M

Permanent magnet motor

CSVW 25 - 160 M Y - 40M

Oil charge: polyolester oil

CSVW 25 - 160 M Y - 40M

Motor code

ATEX special versions

Example

CSHP 8563 - 125 .EX P - 40P

ATEX special design

.EX = device category 2

.X2 = device category 3

.X3 = device category 3 mechanical

Performance data



The BITZER SOFTWARE is available in many languages as a download for Windows as well as a web-based version. It is compatible with any browser and always up to date. The program is also suitable for tablets and smartphones.

The BITZER SOFTWARE covers:

- // Performance data for all common refrigerants under freely selectable operating conditions
- // All relevant technical data
- // Application limits
- // Calculation results and individually defined performance tables for compressors
- // Seasonal calculation
- // Dimensional drawings
- // Parallel compounds
- // Available accessories and their selection
- // All relevant technical documents
- // Further BITZER products

bitzer-software.com

Reference points for evaporating and condensing pressures

Connection positions 1 (HP) and 3 (LP) on the compressor (see dimensional drawing). The pressure drop for shut-off valves and check valves has not been taken into consideration. This is the worldwide state of the art for compact screws, as in factory-produced chillers shut-off valves are often not used and the check valve can also be arranged as an external component in the discharge gas line. For the sake of the international comparability of performance data, this standard was also taken over for the compact screw compressors.

Performance data

Performance data are based on the European Standard EN12900 and 50 Hz operation based on 10 K suction gas superheat, without liquid subcooling. Therefore the rated cooling capacity shows lower values in comparison to data based on 5 or 8.3 K of subcooling.

Evaporating and condensing temperatures correspond to "dew point values" (saturated vapor conditions).

The specified power consumption of the CSV. series includes the operation with frequency inverter and line reactor.

Individual operating points

For detailed compressor selection with the option of individual input data of all load conditions the BITZER SOFTWARE is available.

The screenshot displays the BITZER Software interface. On the left, the 'Compact Screw Compressors CS' section is active, showing the following settings:

- Series: CSVH
- Refrigerant: R513A
- Reference temperature: Dew point temp.
- Compressor selection:
 - Cooling capacity: 300
 - Compressor model: CSVH38-290Y
 - Incl. former types:
- Operating point:
 - Evaporating SST: 5 °C
 - Condensing SDT: 50 °C
 - Operating conditions:
 - with Economiser:
 - Liq. subc. (in condenser): 0 K
 - Suct. gas superheat: 10 K
 - Useful superheat: 100 %
 - Additional cooling: Automatic
 - Max. discharge gas temp.: Auto
 - Extended application range:
 - Power supply:
 - Power frequency: 50Hz
 - Power voltage: 400V-AS (40A)
 - Frequency compressor: 100%

The main window shows a schematic diagram of a compressor system with a green compressor unit and a condenser. The condenser is labeled 'CSVH38-290Y (100.0 %)' and has a temperature of 5.0°C. The evaporator has a temperature of 50.0°C. The discharge gas temperature is 69.1°C. The condensing temperature is 15.0°C. The evaporating temperature is 15.0°C.

The 'Result' tab is selected, showing the following technical data:

Parameter	Value
Compressor	CSVH38-290Y-40A
Frequency compressor	100.0 %
Cooling capacity	717 kW
Cooling capacity *	717 kW
Evaporator capacity	717 kW
Power input	221 kW
Current (400V)	360 A
Voltage range	400V
Condenser Capacity (w. HX)	928 kW
COP/EER	3.24
COP/EER *	3.24
Mass flow LP	21317 kg/h
Mass flow HP	21317 kg/h
min. cooling capacity	190.9 kW
max. cooling capacity	717 kW
Operating mode	Standard
Liquid temp.	50.0 °C
Oil volume flow	0.33 m³/h
Cooling method	-
Discharge gas temp. w/o cooling	69.1 °C



Technical data: CSH

Compressor model	Motor version	Displacement 50/60 Hz m ³ /h ^①	Refrigerating capacity Q ₀			Oil charge dm ³	Motor connection ②	Maximum operating current A	Maximum power consumption 50/60 Hz ^① kW
			R134a R1234yf ^③ R513A ^③ t ₀ /t _c 5°C/50°C kW	R1234ze(E) t ₀ /t _c 5°C/50°C kW	R407C t ₀ /t _c 5°C/50°C kW				
CSH6553-35Y	2	137/165	75.6	57.0	-	8.5	400V(±10%) Δ-3-50Hz 460V(±10%) Δ-3-60Hz Y/Δ	58	34/41
CSH6553-50(Y)	1	137/165	75.1	56.6	106.4	8.5		86	52/63
CSH6563-40Y	2	170/205	94.3	71.3	-	8.5		66	41/49
CSH6563-60(Y)	1	170/205	94.3	71.3	133.7	8.5		108	65/78
CSH6583-50Y	2	195/236	108.8	82.1	-	9		86	51/62
CSH6593-60Y	2	220/266	122.8	92.6	-	9		108	56/68
CSH7553-50Y	2	197/238	106.7	80.7	-	14		79	52/63
CSH7553-70(Y)	1	197/238	108.4	82.0	155.0	14		128	78/94
CSH7563-60Y	2	227/274	125.8	95.1	-	14		98	65/78
CSH7563-80(Y)	1	227/274	125.0	94.5	175.4	14		144	88/106
CSH7673-70Y	2	258/311	150.2	114.5	-	14		123	73/88
CSH7573-70Y	2	258/311	144.6	109.4	-	14		124	78/94
CSH7573-90(Y)	1	258/311	145.0	109.7	204	14		162	96/116
CSH7683-80Y	2	295/356	174.9	131.7	-	14		140	83/100
CSH7583-80Y	2	295/356	168.6	127.2	-	14		144	88/106
CSH7583-100(Y)	1	295/356	169.1	127.6	238	14		170	102/123
CSH7693-90Y	2	336/406	199.2	150.6	-	14		160	96/116
CSH7593-90Y	2	336/406	192.0	144.9	-	14		162	93/112
CSH7593-110(Y)	1	336/406	192.5	145.3	270	14		180	112/135
CSH8553-80Y	2	315/380	177.5	134.0	-	21		400V(±10%) Δ/Δ-3-50Hz 460V(±10%) Δ/Δ-3-60Hz part winding	144
CSH8553-110(Y)	1	315/380	181.7	137.2	257	21	185		112/135
CSH8563-90Y	2	359/433	205	154.4	-	21	155		96/116
CSH8563-125(Y)	1	359/433	207	155.9	293	21	216		132/159
CSH8673-110Y	2	410/495	243	184.1	-	21	195		114/138
CSH8573-110Y	2	410/495	240	180.5	-	21	182		110/133
CSH8573-140(Y)	1	410/495	239	179.7	338	21	246		150/181
CSH8683-125Y	2	470/567	273	210	-	18	221		129/156
CSH8583-125Y	2	470/567	265	199.9	-	18	196		120/145
CSH8583-160(Y)	1	470/567	259	195.4	379	18	260		160/193
CSH8693-140Y	2	535/646	311	237	-	18	254		148/179
CSH8593-140Y	2	535/646	301	228	-	18	214		131/158
CSH8593-180(Y)	1	535/646	302	229	455	18	310		186/224
CSH9553-180(Y)	1	535/646	304	231	444	29	330		205/247
CSH9663-160Y	2	615/742	361	276	-	29	291		173/209
CSH9563-160Y	2	615/742	357	264	-	29	280	155/187	
CSH9563-210(Y)	1	615/742	354	262	505	29	370	246/297	
CSH9673-180Y	2	700/845	420	316	-	29	333	200/241	
CSH9573-180Y	2	700/845	417	310	-	29	310	175/211	
CSH9573-240(Y)	1	700/845	409	304	601	29	420	255/308	
CSH9683-210Y	2	805/972	486	366	-	29	383	226/273	
CSH9583-210Y	2	805/972	480	358	-	29	320	204/246	
CSH9583-280(Y)	1	805/972	472	352	689	29	450	280/338	
CSH9693-240Y	2	910/1098	552	414	-	29	384	255/308	
CSH9593-240Y	2	910/1098	546	407	-	29	360	222/268	
CSH9593-300(Y)	1	910/1098	546	407	783	29	450	280/338	
CSH96103-280Y	2	1015/1225	594	454	-	31	456	271/327	
CSH95103-280Y	2	1015/1225	588	440	-	31	413	254/307	
CSH95103-320(Y)	1	1015/1225	588	440	868	31	566	332/401	
CSH96113-320Y	2	1120/1351	651	507	-	31	510	301/363	
CSH95113-320Y	2	1120/1351	644	481	-	31	447	277/334	

Technical data

Technical Data: CS PRO

Compressor model	Motor version	Displacement 50/60 Hz m ³ /h ^①	Refrigerating capacity Q _o	Heating capacity Q _h ^⑤	Oil charge dm ³	Motor connection ②	Maximum operating current A	Maximum power consumption 50/60 Hz ^① kW
			R290 t ₀ / t _c 5°C / 50°C kW	R600a t ₀ / t _c 35°C / 85°C kW				
CSHP6553-50Z	2	137/165	101.5	-	8.5	400V(±10%) Δ-3-50Hz 460V(±10%) Δ-3-60Hz Y/Δ	81	46/56
CSHP6563-60Z	2	170/205	127.4	-	8.5		96	56/68
CSHP7553-70Z	2	197/238	146.0	154.5	14		114	67/81
CSHP7553-80Z	1	197/238	146.1	-	14		127	77/93
CSHP7563-80Z	2	227/274	166.5	176.5	14		129	75/91
CSHP7563-90Z	1	227/274	166.6	-	14		146	84/101
CSHP7573-90Z	2	258/311	192.4	203	14		137	82/99
CSHP7673-90Z	2	258/311	196.2	-	14		137	82/99
CSHP7573-100Z	1	258/311	192.5	-	14		161	96/116
CSHP7673-100Z	1	258/311	196.2	-	14		157	94/113
CSHP7583-100Z	2	295/356	224	237	14		163	97/117
CSHP7683-100Z	2	295/356	223	-	14		163	97/117
CSHP7583-110Z	1	295/356	224	-	14		180	107/129
CSHP7683-110Z	1	295/356	223	-	14		176	105/127
CSHP7593-110Z	2	336/406	255	269	14		180	107/129
CSHP7693-110Z	2	336/406	254	-	14		180	107/129
CSHP8553-110Z	2	315/380	240	253	21		180	107/129
CSHP8553-125Z	1	315/380	240	-	21		216	126/152
CSHP8563-125Z	2	359/433	273	288	21		201	117/141
CSHP8563-140Z	1	359/433	274	-	21		244	144/174
CSHP8573-140Z	2	410/495	316	332	21		222	129/156
CSHP8673-140Z	2	410/495	318	-	21		222	129/156
CSHP8573-180Z	1	410/495	316	-	21		286	162/196
CSHP8673-180Z	1	410/495	318	-	21		270	153/185
CSHP8583-160Z	2	470/567	348	366	19		253	147/177
CSHP8683-160Z	2	470/567	349	-	19		253	147/177
CSHP8583-180Z	1	470/567	348	-	19		310	178/215
CSHP8683-180Z	1	470/567	349	-	19		303	173/209
CSHP8593-180Z	2	535/646	408	424	19	283	160/193	
CSHP8693-180Z	2	535/646	397	-	19	283	160/193	
CSHP9553-160Z		535/646	-	421	29	281	166/200	
CSHP9553-180Z	2	535/646	398	-	29	310	186/224	
CSHP9563-180Z		615/742	-	490	29	304	182/220	
CSHP9563-210Z	2	615/742	460	-	29	375	221/267	
CSHP9663-210Z	2	615/742	477	-	29	381	225/272	
CSHP9573-210Z		700/845	-	568	29	347	204/246	
CSHP9573-240Z	2	700/845	535	-	29	434	255/308	
CSHP9673-240Z	2	700/845	546	-	29	431	255/308	
CSHP9583-240Z		805/972	-	649	29	396	232/280	
CSHP9583-280Z	2	805/972	624	-	29	510	302/364	
CSHP9683-280Z	2	805/972	635	-	29	507	300/362	
CSHP9593-280Z		910/1098	-	747	29	433	255/308	
CSHP95103-320Z		1015/1225	-	826	31	530	312/377	
CSHP95113-320Z		1120/1351	-	900	31	570	336/406	

Indicate refrigerant when ordering the compressor.
Tentative data: Refrigerating and heating capacity as well as electrical data

Legend see page 30.

Technical Data: Compressors for high temperature heat pumps

Compressor model	Motor-version	Displacement 60 Hz m ³ /h ^①	Wärmeleistung Q _h ^⑥ ECO-Betrieb		Oil charge dm ³	Motor connection ④	Maximum operating current A ^④	Maximum power consumption kW ^④
			R1233zd(E) t ₀ / t _c 50°C / 120°C kW	R1233zd(E) t ₀ / t _c 70°C / 120°C kW				
CSH2T9563-180Y		742	458	731	29	FI operation in Δ-direct-on-line start 360-400V Δ-3-60Hz	352	195
CSH2T9573-210Y		845	513	821	29		381	211
CSH2T9583-240Y		972	585	949	29		441	250
CSH2T9593-280Y		1098	654	1062	29		494	293

Legend for the pages 28 to 31

- ① 50 Hz: 2900 min⁻¹, 60 Hz: 3500 min⁻¹
CSH2T: 60 Hz: 3500 min⁻¹
- ② Basis for motor data:
CS.65, CS.75 and CS.85: part winding motor (PW, Δ/ΔΔ).
Data for Y/Δ design upon request.
CS.95 and CS.105: star-delta motor (Y/Δ)
Consider the maximum operating current for the selection of contactors, cables and fuses.
Contactors: operational category AC3.
PW: Select both motor contactors for approx. 60% of the maximum operating current.
Y/Δ: Select the contactors according to contactor manufacturer's instructions. Consider the maximum operating current.
- ③ The indicated cooling capacity is valid for R134a.
Deviations of cooling capacities:
R1234yf: 5°C/50°C approx. 94% and 5°C/38°C approx. 97%.
R513A: 5°C/50°C approx. 101% and 5°C/38°C approx. 104%..

- ④ Basis for motor data:
60 Hz with frequency inverter (FI)
Connect motor in delta direct-on-line start.
Operation permissible with BITZER frequency inverter (FI) only.
Select electrical components according to the specifications of the FI manufacturer.

Heating capacity is the sum of refrigerating capacity and power consumption.

- ⑤ The CSHP heating capacity data for R600a are based on operation at 50 Hz, 20 K suction gas superheat without liquid subcooling.
- ⑥ The CSH2T heating capacity data are based on operation at 60 Hz, 5 K suction gas superheat and ECO operation with liquid subcooling at: t_{eco} + 10 K.

Technical Data: CSW

Compressor model	Motor version	Displacement 50/60 Hz m ³ /h ^①	Refrigerating capacity Q _o			Oil charge dm ³	Motor connection ②	Maximum operating current A	Maximum power consumption 50/60 Hz ^① kW	
			R134a R1234yf ^③ R513A ^③ t ₀ /t _c 5°C/38°C kW	R1234ze(E) t ₀ /t _c 5°C/38°C kW	R407C t ₀ /t _c 5°C/38°C kW					
CSW6583-40Y	2	195/236	126.6	94.2	-	9	400V(±10%)Δ-3-50Hz 460V(±10%)Δ-3-60Hz Y/Δ	74	43/52	
CSW6583-50(Y)	1	195/236	-	-	183.4	9		92	55/66	
CSW6593-50Y	2	220/266	142.5	106.1	-	9		84	47/57	
CSW6593-60(Y)	1	220/266	-	-	217	9		105	62/75	
CSW7573-60Y	2	258/311	174.3	129.8	-	14		98	55/66	
CSW7573-70(Y)	1	258/311	-	-	255	14		123	73/88	
CSW7583-70Y	2	295/356	198.3	147.7	-	14		112	64/77	
CSW7583-80(Y)	1	295/356	-	-	290	14		140	83/100	
CSW7593-80Y	2	336/406	226	168.2	-	14		128	72/87	
CSW7593-90(Y)	1	336/406	-	-	330	14		160	95/115	
CSW8573-80Y	4	410/495	282	210	-	20		400V(±10%)Δ-3-50Hz 460V(±10%)Δ-3-60Hz part winding Y/Δ	118	72/87
CSW8573-90Y	2	410/495	283	211	-	20			156	87/105
CSW8573-110(Y)	1	410/495	-	-	412	20			195	116/140
CSW8583-90Y	4	470/567	309	230	-	17			135	80/97
CSW8583-110Y	2	470/567	306	228	-	17			177	96/116
CSW8583-125(Y)	1	470/567	-	-	455	17	221		127/153	
CSW8593-110Y	4	535/646	349	260	-	17	156		90/109	
CSW8593-125Y	2	535/646	349	260	-	17	203		109/132	
CSW8593-140(Y)	1	535/646	-	-	517	17	254		144/174	
CSW9563-125Y	4	615/742	431	320	-	27	400V(±10%)Δ-3-50Hz 460V(±10%)Δ-3-60Hz Y/Δ		192	105/127
CSW9563-140Y	2	615/742	425	316	-	27			233	132/159
CSW9563-160(Y)	1	615/742	-	-	624	27			291	175/211
CSW9573-140Y	4	700/845	482	352	-	27			213	125/151
CSW9573-160Y	2	700/845	486	355	-	27			266	147/177
CSW9573-180(Y)	1	700/845	-	-	714	27			333	198/239
CSW9583-160Y	4	805/972	565	421	-	27		238	140/169	
CSW9583-180Y	2	805/972	558	416	-	27		306	167/202	
CSW9583-210(Y)	1	805/972	-	-	829	27		383	223/269	
CSW9593-180Y	4	910/1098	640	476	-	27		263	155/187	
CSW9593-210Y	2	910/1098	634	472	-	27		345	186/224	
CSW9593-240(Y)	1	910/1098	-	-	940	27		431	252/304	
CSW95103-210Y	4	1015/1225	687	511	-	29		307	179/216	
CSW95103-240Y	2	1015/1225	686	510	-	29		378	220/266	
CSW95103-280(Y)	1	1015/1225	-	-	1012	29		456	272/328	
CSW95113-240Y	4	1120/1351	771	574	-	29	335	196/237		
CSW95113-280Y	2	1120/1351	760	566	-	29	411	240/290		
CSW95113-320(Y)	1	1120/1351	-	-	1123	29	510	297/358		
CSW10563-210Y	4	1170/1401	795	604	-	32	327	185/223		
CSW10563-240Y	2	1170/1401	798	606	-	32	394	246/297		
CSW10573-240Y	4	1400/1690	952	722	-	32	377	217/262		
CSW10573-290Y	2	1400/1690	955	725	-	32	454	284/343		
CSW10583-290Y	4	1700/2052	1148	868	-	32	454	276/333		
CSW10583-360Y	2	1700/2052	1152	871	-	32	565	340/410		
CSW10593-360Y	4	2000/2414	1373	1043	-	32	565	340/410		
CSW10593-400Y	2	2000/2414	1378	1047	-	32	629	382/461		

Legend see page 30.



Technical Data: CSVH and CSVW

Compressor model	Displacement at maximum speed m ³ /h	Refrigerating capacity Q _o ^①				Oil charge dm ³	Frequency inverter connection	Maximum operating current ^②		Maximum power consumption kW
		R134a		R1234ze(E)				A ^③	A ^④	
		t ₀ /t _c 5°C / 50°C kW	t ₀ /t _c -10°C / 45°C kW	t ₀ /t _c 5°C / 50°C kW	t ₀ /t _c -10°C / 45°C kW					
CSVH24-125Y CSVH24-125MY	464	281	161	213	118	15	380...480V / 3 / 50 Hz 380...480V / 3 / 60 Hz	220	190	130
CSVH25-160Y CSVH25-160MY	580	358	203	271	149	15		260	225	167
CSVH26-200Y CSVH26-200MY	725	439	246	326	176	15		340	290	198
CSVH37-240Y	960	593	338	446	250	35		420	370	250
CSVH38-290Y	1156	712	405	536	300	35		490	430	290
CSVW24-125Y CSVW24-125MY	464	285	160	213	119	15	380...480V / 3 / 50Hz 380...480V / 3 / 60Hz	220	190	126
CSVW25-160Y CSVW25-160MY	580	359	201	268	149	15		260	225	162
CSVW26-200Y CSVW26-200MY	725	439	245	327	179	15		340	290	198
CSVW37-240Y	1000	582	328	437	243	35		420	370	250
CSVW38-290Y	1206	705	399	526	292	35		490	430	290

Indicate refrigerant when ordering the compressor.

Permanent magnet motor: CSV..MY.

The efficiency difference is particularly noticeable at part load.

See page 17.

① Performance data at maximum compressor speed. They are based on the European Standard EN12900 and 50 Hz operation, relating to 10 K suction gas superheat without liquid subcooling. Performance data for individual operating conditions and part load operation for see BITZER SOFTWARE.

② Consider the max. operating current or max. power consumption at max. speed for the selection of cables and fuses.
Fuses: Semiconductor fuses with aR or gR characteristics

③ Nominal supply voltage (FI input voltage)
400V-3-50/60Hz

④ Nominal supply voltage (FI input voltage)
460V-3-50/60Hz

Dimensional drawings

The following pages show the dimensional drawings of the compressors in their standard scope of delivery. CAD data of the compressors including all options can be found as 2D dxf drawings and 3D STP models on the website www.bitzer.de and in the BITZER SOFTWARE.

Dimensional drawings for CS PRO

The model designations CSH.5 and CSH.6 on the following pages include the respective CSHP.5 and CSHP.6 models.

Connection positions

- | | |
|----------|--|
| 1 | High pressure connection (HP):
Connection for high pressure switch (HP) |
| 2 | Additional high pressure connection (HP) |
| 2a | Connection for high pressure transmitter (HP)
CSW105: connected to the compressor module |
| 3 | Low pressure connection (LP):
Connection for low pressure switch (LP) |
| 3a | Connection for low pressure transmitter (LP)
CSW105: connected to the compressor module |
| 4 | Oil sight glass |
| 5 | Oil valve for maintenance (standard scope of delivery) / connection for oil equalisation (with parallel operation) |
| 6 | Oil drain plug (motor housing) |
| 8 | Connection for opto-electronic oil level switch - (OLC-D1-S)
CSW105: connected to the compressor module
CSV.: integrated into FI control |
| 9 | Oil heater with heater sleeve (standard)
CSW105: connected to the compressor module
CSV.: integrated into FI control |
| 10 | Oil pressure connection |
| 11 | Connections for external oil cooler
(optional adaptor) |
| 11a | Outlet to oil cooler |
| 11b | Inlet/return from oil cooler |
| 12 | Oil temperature sensor
CSW105: connected to the compressor module
CSV.: integrated into FI control |
| 13 | Connection for economiser (ECO, optional shut-off valve, CSH and CSVH with pulsation muffler) |
| 14 | Gewindebohrung für Rohrhalterung |
| 14a | for ECO line |
| 14b | for LI line |
| 15 | Connection for liquid injection
(LI, optional shut-off valve) |
| 16 | Earth screw for housing |
| 17 | CSW and CSVW only: Connection for oil and gas return (for systems with flooded evaporator, optional adaptor) |
| 18 | Oil filter (maintenance connection) |
| 19 | FI cooling (liquid refrigerant) |
| 20 | Frequency inverter (FI) |
| 21 | Oil injection valve (internal) |
| 22 | Compressor module |
| 23 | Slider position indicator |
| 24 | Gas permeable plug |
| SL | Suction gas line |
| DL | Discharge gas line |
| X | Removal space for oil filter |
| X1 .. X4 | Plan a removal space for FI housing. |

Dimensional drawings

CSH65

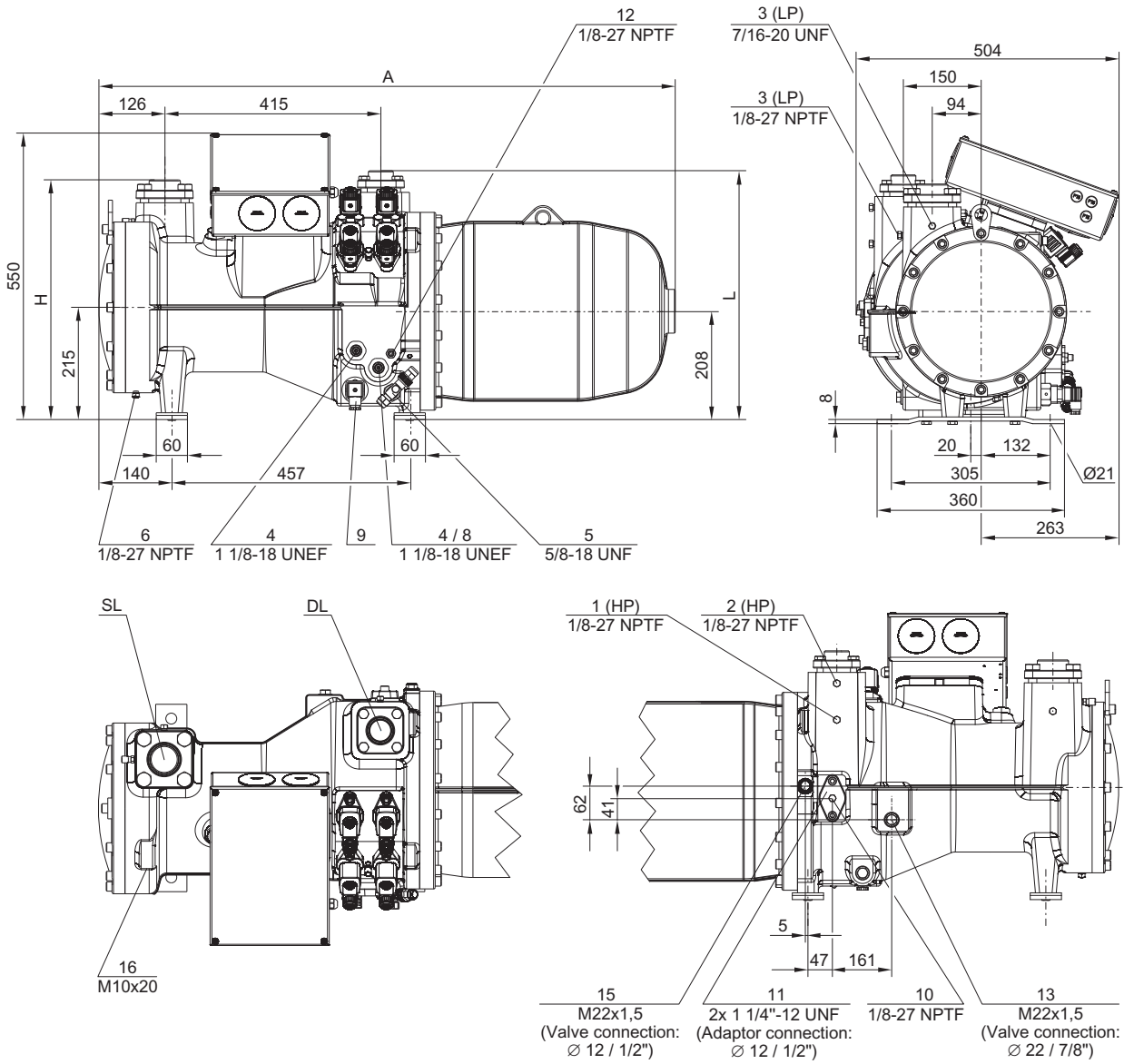

	A	H	L	DL	SL
	mm	mm	mm	mm	mm
CSH6553	1107	460	478	Ø42	Ø54
CSH6563				(1 ⁵ / ₈ "	(2 ¹ / ₈ "
CSH6583	1207	470	481	Ø54	Ø64
CSH6593				(2 ¹ / ₈ "	(2 ⁵ / ₈ "

Dimensional drawings

CSW65

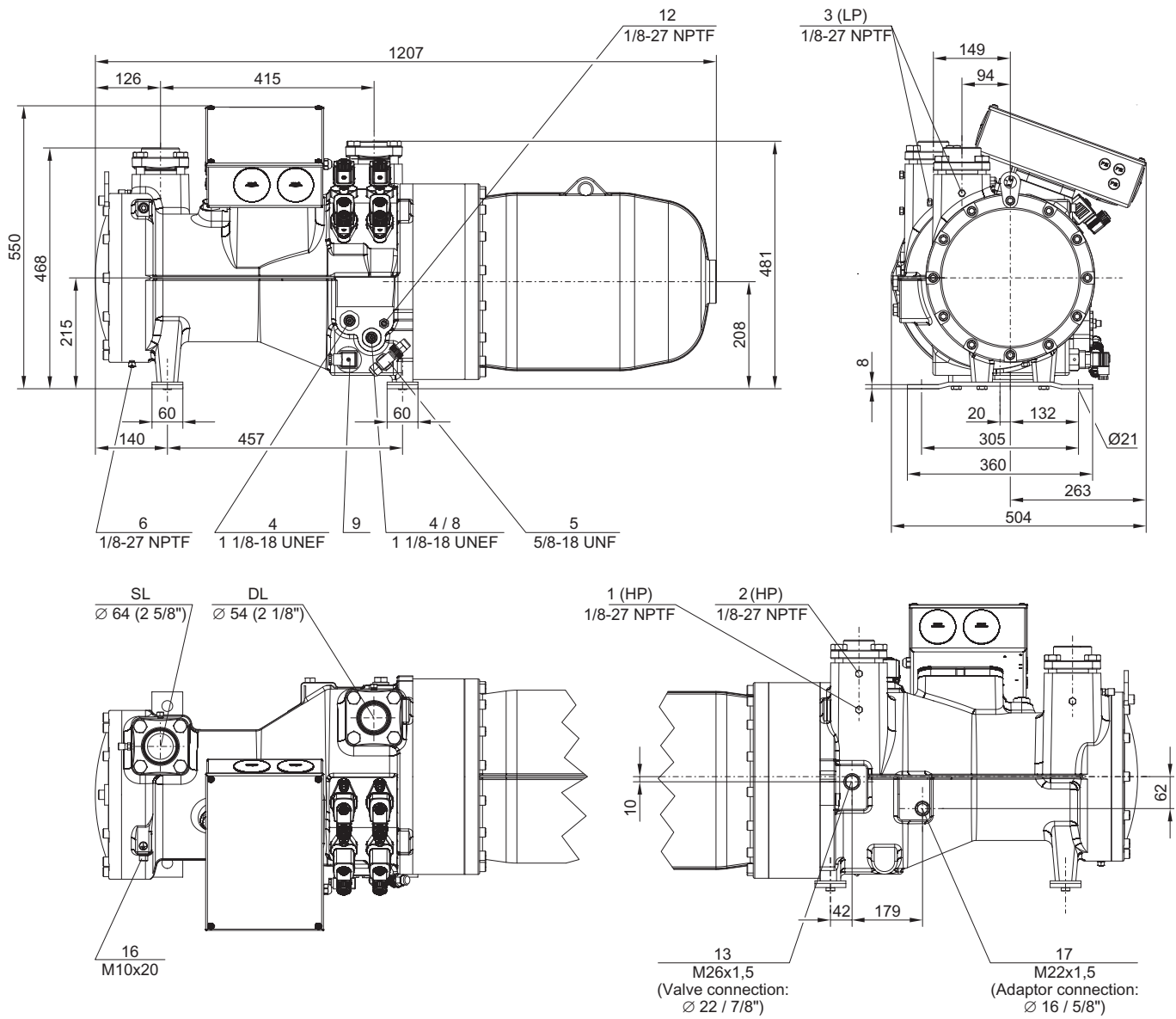

Connection positions see page 33.

Dimensional drawings

CSH75

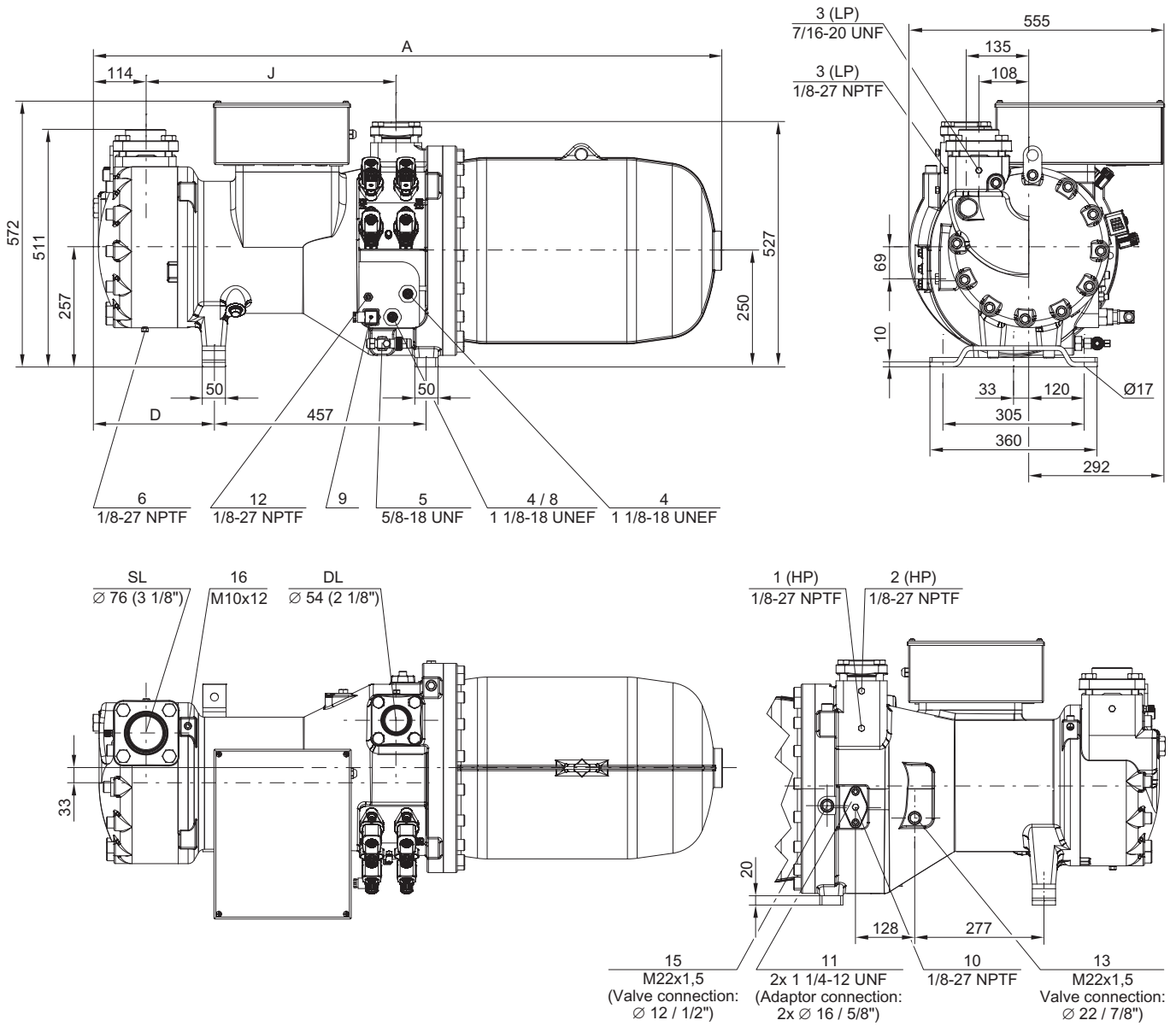

	A mm	D mm	J mm
CSH7553 / CSH7563 / CSH7573 CSH7583-80Y / CSH7593-90Y	1354	262	540
CSH7583-100(Y) CSH7593-110(Y)	1385	293	570

Connection positions see page 33.

Dimensional drawings

CSH76 and CSW75

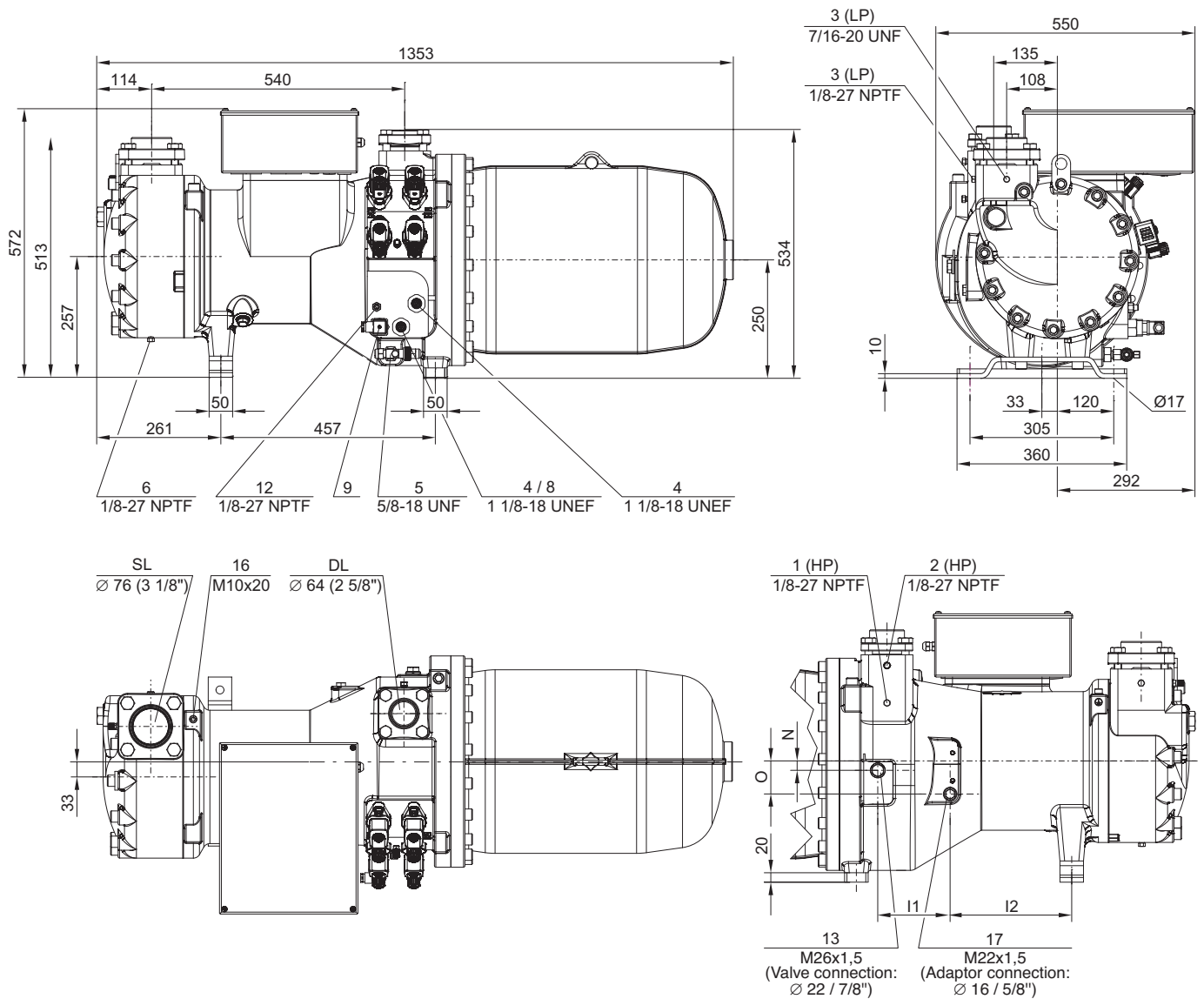

	l1 mm	l2 mm	N mm	O mm
CSH7673 CSW7573	153	258	20	70
CSH7683 / CSH7693 CSW7583 / CSW7593	157	261	23	69

Connection positions see page 33.

Dimensional drawings

CSH85

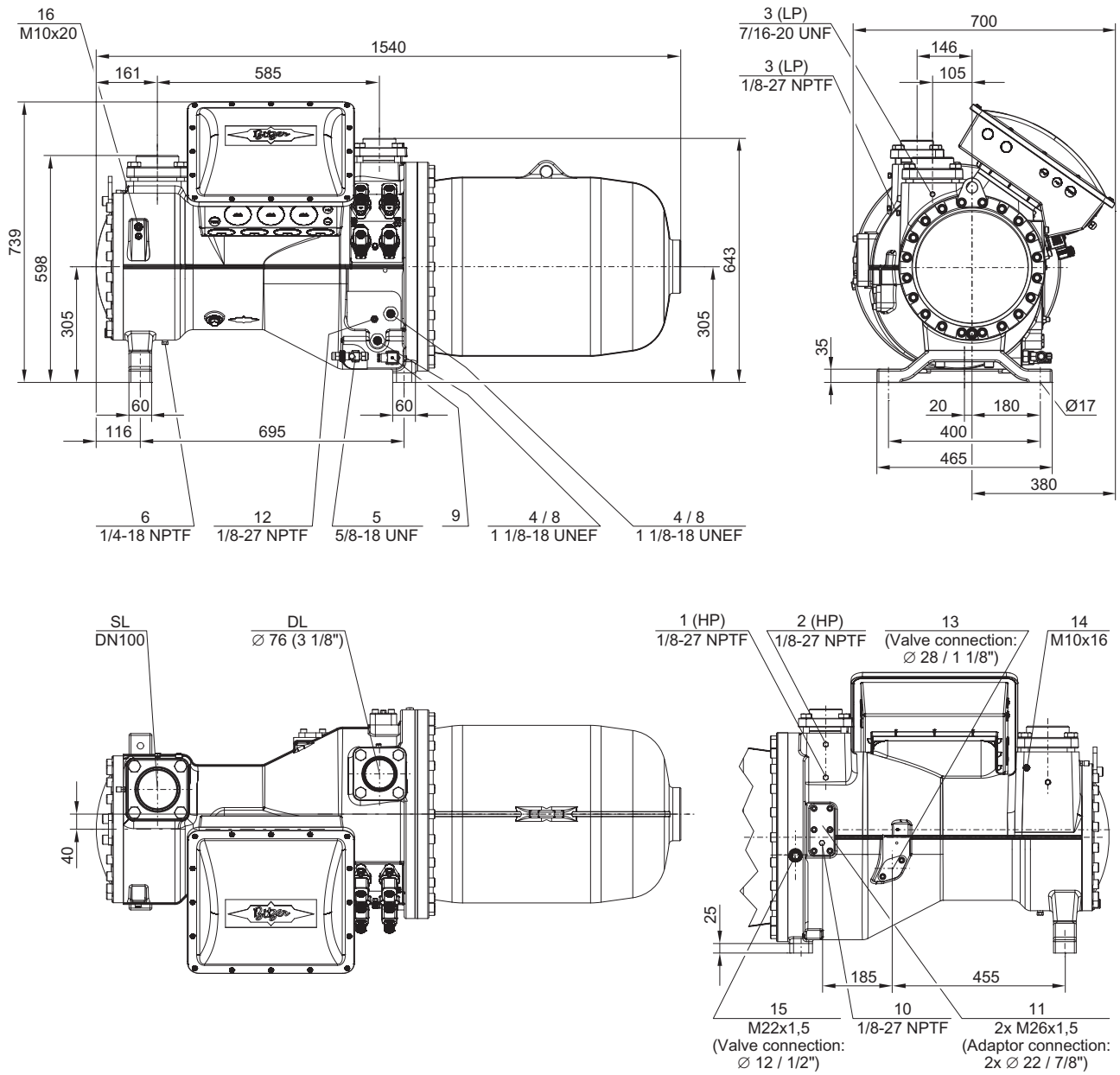

Connection positions see page 33.

Dimensional drawings

CSH86 and CSW85

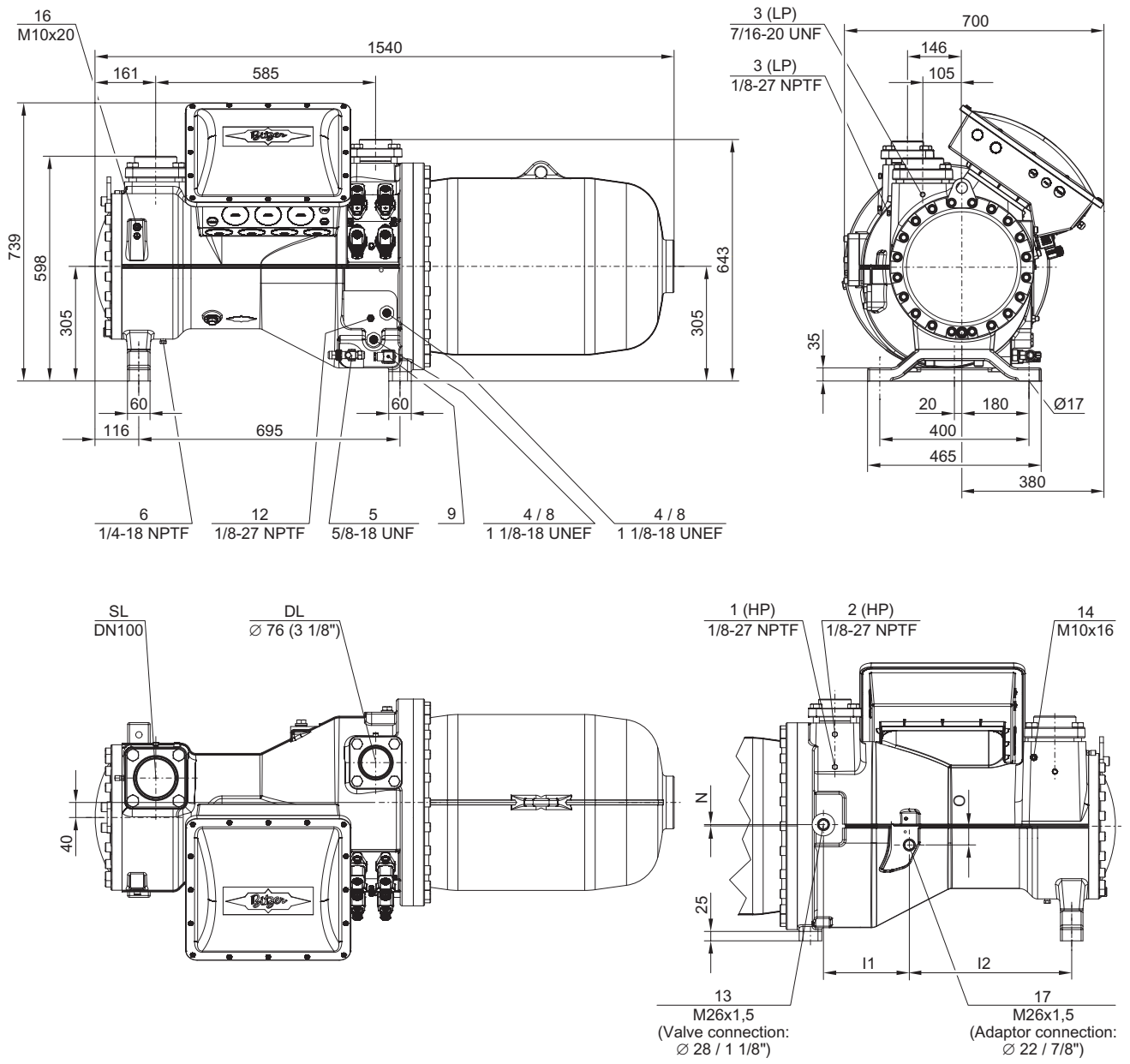

	l1 mm	l2 mm	N mm	O mm
CSH8673 CSW8573	221	434	0	56
CSH8686 / CSH8693 CSW8583 / CSW8593	228	432	4	50

Connection positions see page 33.

Dimensional drawings

CSH95 and CSH2T95

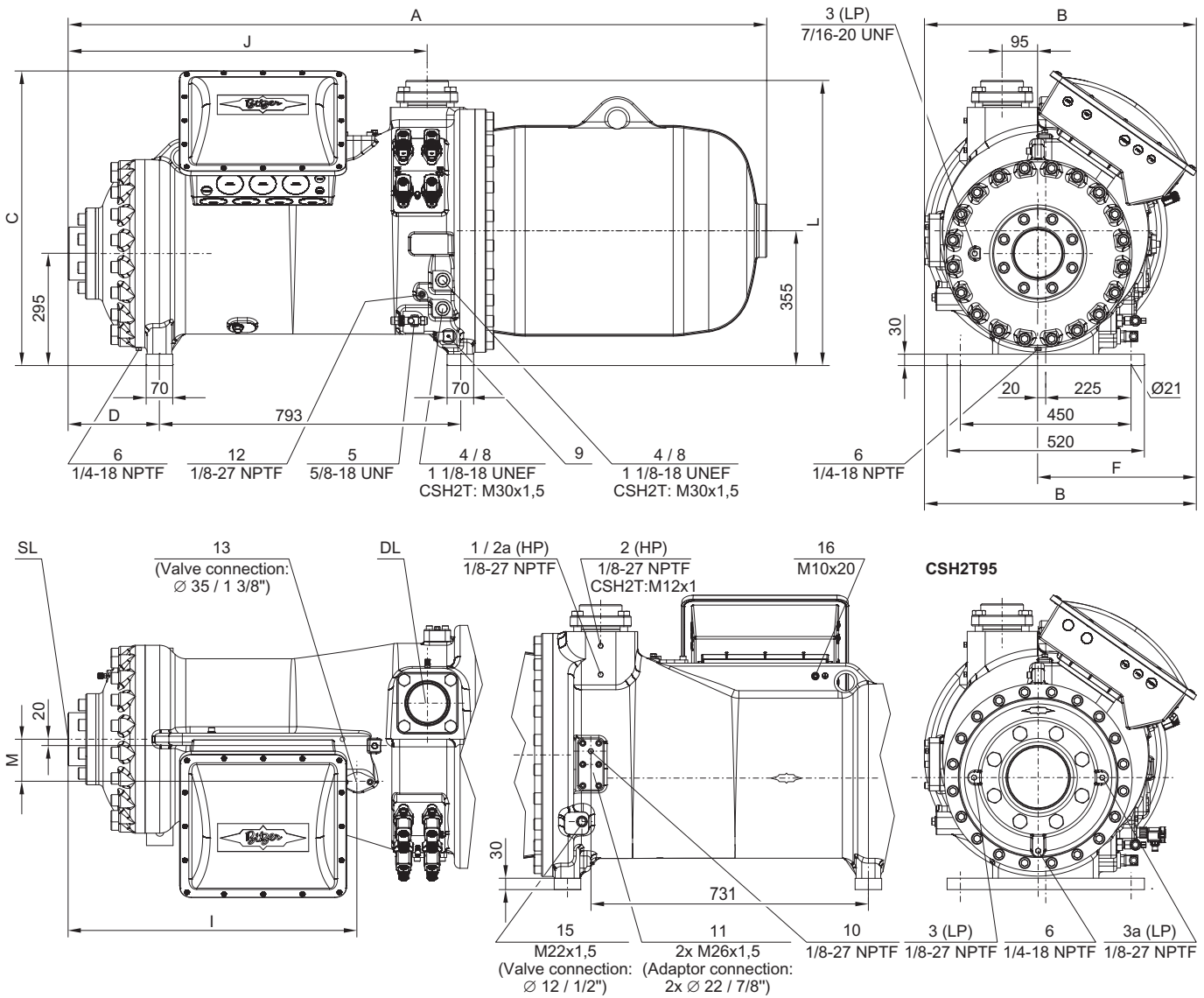

	A mm	B mm	C mm	D mm	F mm	I mm	J mm	L mm	M mm	DL mm	SL mm
CSH9553 CSH9563 CSH9673	1824	717	776	242	417	764	930	743	106	$\varnothing 76$ (3 1/8")	DN100
CSH9583-210Y CSH9593-240Y	1842	717	776	242	417	764	948	752	113	DN100	DN125
CSH9583-280(Y) CSH9593-300(Y)	1869	717	776	269	417	791	975	752	113	DN100	DN125
CSH95103-280Y	1955	731	796	269	431	790	974	760	113	DN100	DN125
CSH95103-320(Y) CSH95113	1975	731	796	289	431	810	994	760	113	DN100	DN125
CSH2T9563 CSH2T9573	1896	717	776	296	417	817	1001	743	106	$\varnothing 76$ (3 1/8")	DN150
CSH2T9583 CSH2T9593	1896	717	776	296	417	817	1001	752	113	DN100	DN150

Connection positions see page 33.

Using larger suction gas flanges changes the dimensions A, D, I and J.

Dimensional drawings

CSH96 and CSW95

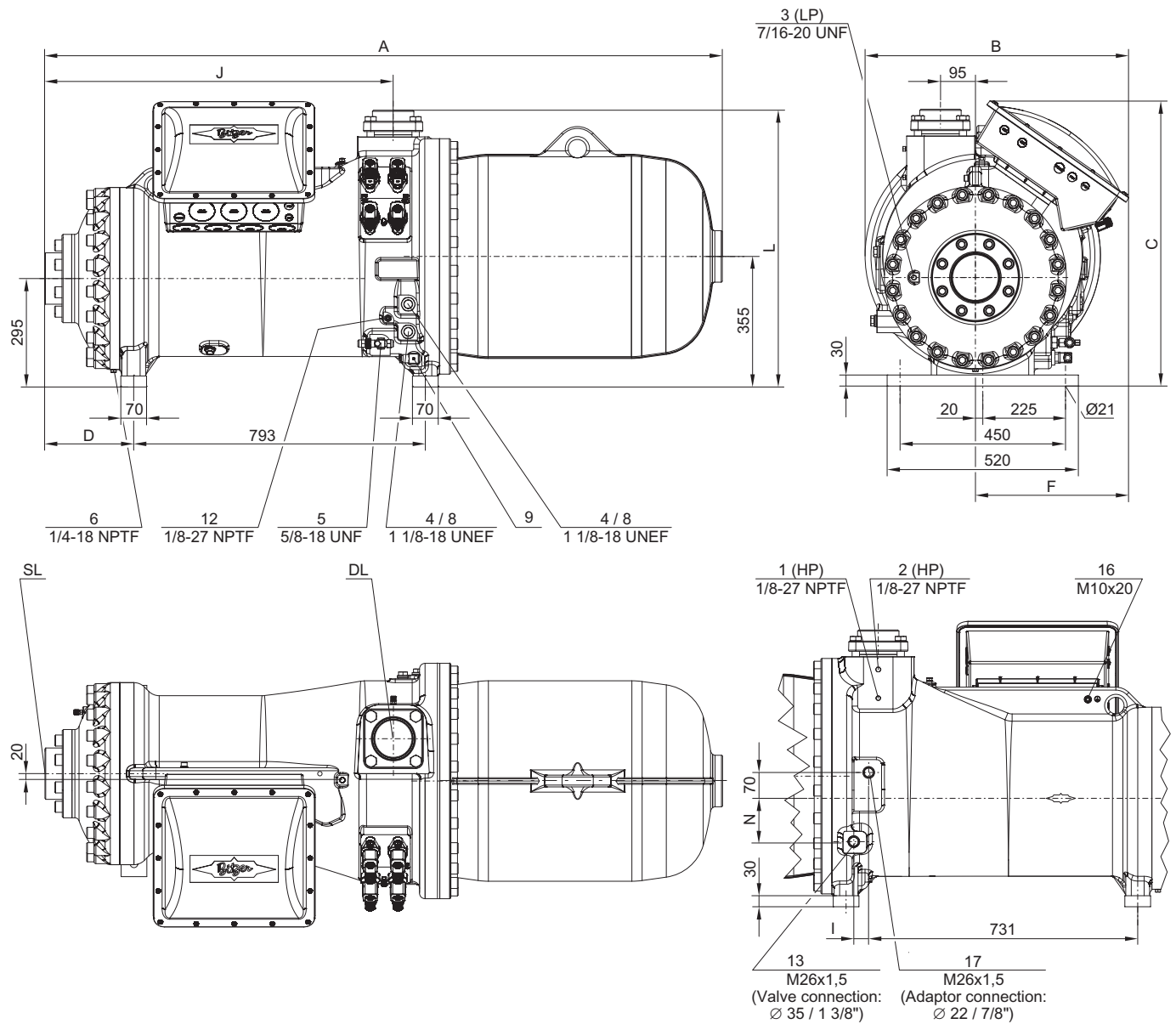

	A	B	C	D	F	I	J	L	N	DL	SL
	mm	mm	mm	mm	mm	mm	mm	mm	mm	mm	mm
CSH9663 / CSH9673 CSW9563 / CSW9573	1824	717	776	224	417	41	930	751	118	Ø76 (3 1/8")	DN100
CSH9683 / CSH9693 CSW9583 / CSW9593	1842	717	776	242	417	34	948	751	122	DN100	DN125
CSW95103-240Y	1927	731	796	242	431	26	948	751	120	DN100	DN125
CSH96103-280Y CSW95103-280(Y) CSW95113-280Y	1955	731	796	269	431	26	975	751	120	DN100	DN125
CSH96113-320Y CSW95113-320(Y)	1974	731	796	289	431	26	994	751	120	DN100	DN125

Connection positions see page 33.

Using larger suction gas flanges changes the dimensions A, D, I and J.

	A mm	F mm	I mm	J mm	N mm	O mm	S mm	U mm
CSW10563 CSW10573	2310	1069	380	591	454	336	163	1090
CSW10583 CSW10593	2354	1113	380	595	354	330	138	1134

Dimensional drawings

CSVH2

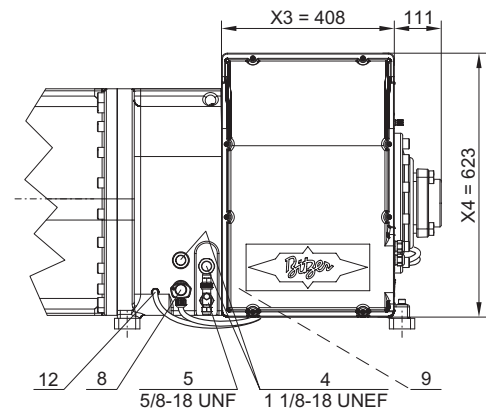
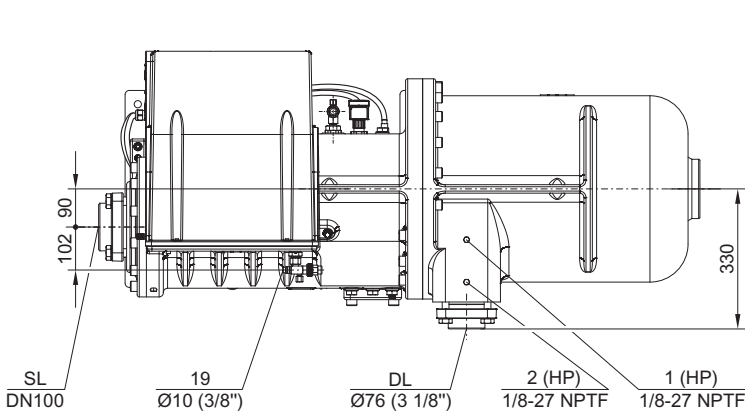
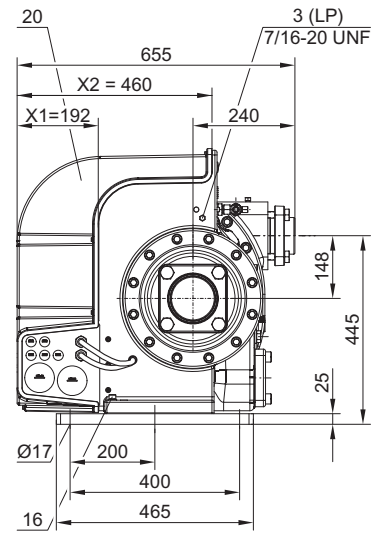
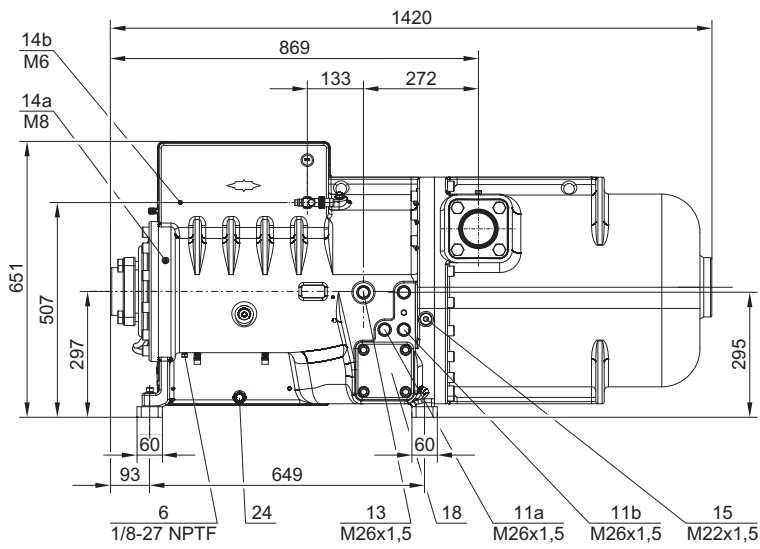

Optional alternative suction gas connection: DN125
This flange is 14 mm longer.

Dimensional drawings

CSVW2

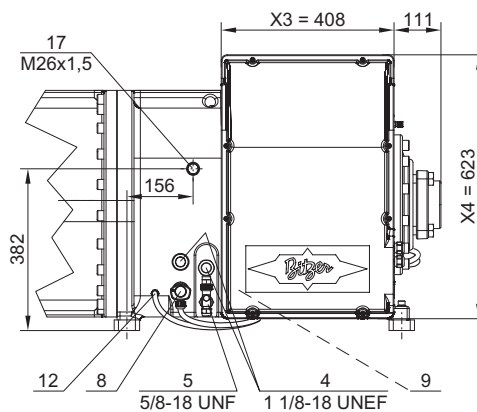
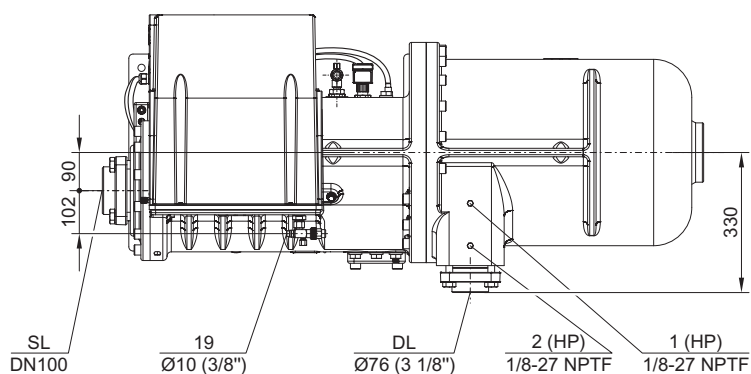
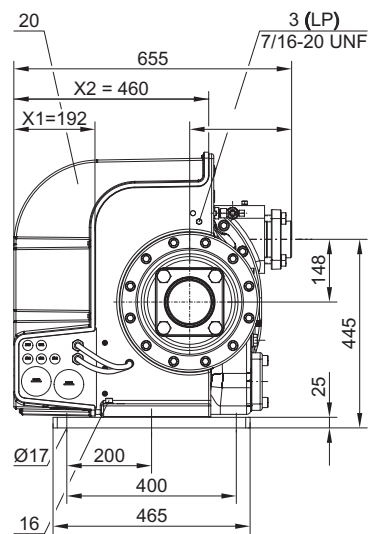
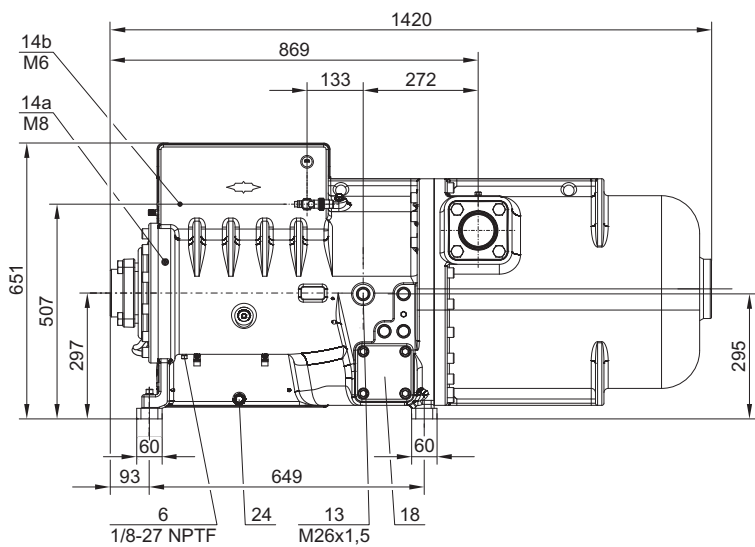

Optional alternative suction gas connection: DN125
This flange is 14 mm longer.

Connection positions see page 33.

Dimensional drawings

CSVW3

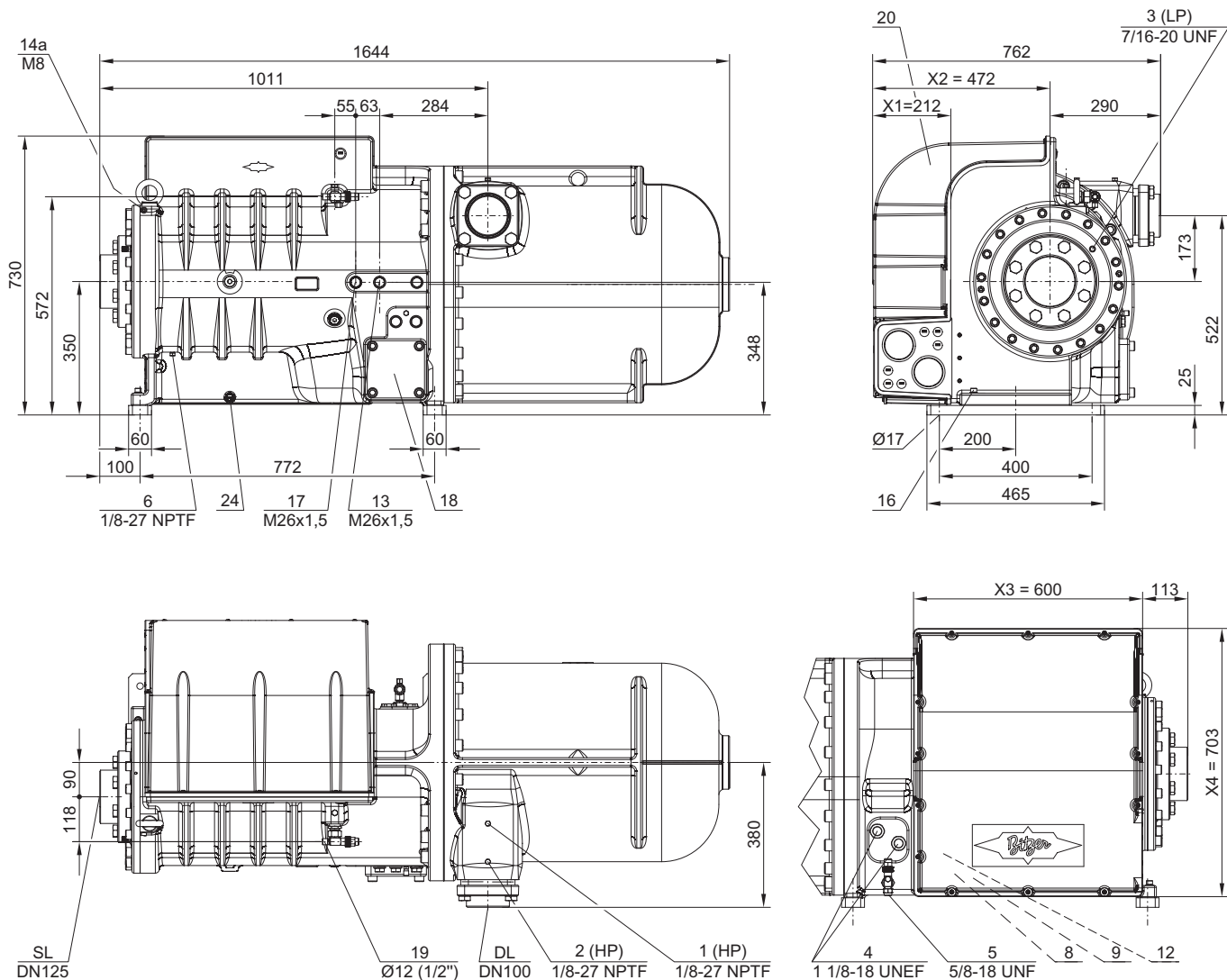

Connection positions see page 33.

ALWAYS NEARBY.
BITZER WORLDWIDE.



BITZER Kühlmaschinenbau GmbH

Peter-Schaufler-Platz 1 // 71065 Sindelfingen // Germany

Tel +49 (0)70 31 932-0 // Fax +49 (0)70 31 932-147

bitzer@bitzer.de // www.bitzer.de

Subject to change // www.bitzer.de/emppo // 03.2026